

**ISO 9001**  
CERTIFIED

# shindaiwa

OWNER'S AND

OPERATOR'S MANUAL

SOUND PROOF DIESEL  
ENGINE  
GENERATOR/WELDER

## *DGW500DM*

Vertical, Water-Cooled  
4-Cycle Diesel Engine

Table of Contents	Page
1.Safety Guidelines	2
2.Specifications	5
3.Use	5
4.Parts	6
5.Equipment	8
5-1. Welding Output Control	8
5-2. VRD	9
5-3. Output Remote Control	9
5-4. Meter	10
5-5. Monitor Lamp	11
5-6. Earth Leakage Relay	13
5-7. Auto Idle Feature	14
5-8. Emergency Stop Switch	14
5-9. Battery Isolator	14
6.Initialization and Pre-check	15
6-1.Checking Engine Oil	15
6-2.Checking Coolant/Water	15
6-3.Checking Fuel	16
6-4.Checking Fuel, Engine Oil and Water Leakage	17
6-5.Checking Battery	17
7.Operation	18
7-1.Starting	18
7-2.Stopping	19
7-3.Emergency Stopping	19
8.Welding Operation	20
8-1.Selection-Welding Cable	20
8-2.Polarity	20
8-3.Connection-Welding Cable	21
8-4.Duty Cycle	22
8-5.Welding	22
9.Generator Operation	23
9-1.Output Range	23
9-2.Output Limitation	24
9-3.Operation	24
10.Simultaneous Use of Welding and Generating	26
11.Checking and Maintenance	26
12.Long-term Storage	31
13.Troubleshooting	32
13-1.Symptom and Countermeasures	32
13-2.Error Code Display	34
14.Engine Wiring Diagram	35
15.Generator Wiring Diagram	36



CAUTION: Do not operate the Generator/Welder, or any other appliance, before you have read and understood the instructions for use.





## Introduction

Thank you for purchasing Shindaiwa Sound Proof Diesel Engine Generator/Welder.

- This user manual was created to ensure the safe operation of this equipment. Therefore, the manufacturer of this equipment strongly recommends that the user follow the instructions herein, to avoid unnecessary accidents and repairs.
- Please operate this equipment after thoroughly reviewing and understanding the contents of this manual.
- Please attach this manual, if the equipment will be sub-leased.
- Please store this manual near the equipment for easy reference.

■ Following convention will be used throughout the manual to indicate the degree of cautions.

 <b>Danger</b>	<i>Can cause serious injuries or death.</i>
 <b>Caution</b>	<i>Can cause minor injuries or damage to the equipment or other properties.</i>
<b>&lt;Caution&gt;</b>	<i>Other types of caution</i>

- Even some of the items noted in 『 **Caution**』 may lead to serious injuries. Please read all item and follow all the safety guidelines.

## 1. Safety Guidelines

### **Danger : Suffocation from exhaust fume**

- Exhaust fume from the engine contains many elements harmful to human. Do not operate this equipment in poorly ventilated area, such as inside a room or in a tunnel.

### **Danger : Electric Shock**

- Close all doors and place locks during operation.
- Do not touch the output terminals during operation.
- Do not insert metal objects (such as pin or wire) into plug-in receptacles.
- Do not touch wiring or electric parts inside the equipment during operation.
- Ground every grounding terminal to the earth as set out in the manual. If even one of all is disconnected by mistake or accidents, it will be much more dangerous for human body than the NO RELAY case, because leaking current inevitably goes through the body.
- Even though all the terminals of the loads have been grounded to the earth, the bonnet (canopy) grounding terminal should be grounded to the earth.
- Before connecting or disconnecting a plug from output receptacle, always turn the circuit breaker to OFF position.
- Before connecting or disconnecting a welding cable from output terminals, stop the engine, and remove the engine key.
- Before performing any equipment check or maintenance, stop the engine, and remove the engine key. A person performing the maintenance should always keep the key.

### **Danger : Burns**

- Do not open the radiator cap while operating this equipment or immediately after stopping the equipment, to avoid sustaining burns from hot vapor.

### **Danger : Injuries**

- Close all doors and place locks during operating this equipment, to avoid injuries by unintentional touching cooling fan and fan belt.

### **Caution : Suffocation from exhaust fume**

- Do not point the exhaust fume toward pedestrians or building.

### **Caution : Suffocation from welding fume**

- Be sure to wear a fume proof mask in operation, because welding fume contains poisonous gas and dust. Pay attention to the airflow direction and sufficient ventilation also in order to prevent from inhaling the fume.

### **Caution : Injuries to eyes and skin**

- Be sure to wear spark protection glass(es), long-sleeve shirts, gloves, etc. in order to protect eyes and skin from harmful spark in welding.
- Battery fluid contains diluted sulfuric acid. Avoid contact with eyes, skin or on clothing. If the acid comes in contact, especially with eyes, flush with a lot of water, and contact your physician immediately.

### **Caution : Electric shock**

- Do not flush water onto the equipment nor operate it in the rain.

**⚠ Caution : Explosion**

- Do not use the equipment or charge the battery, in the case the battery fluid level is lower than the LOWER level.
- Battery may emit some combustible gas, so keep it away from fire and sparks.

**⚠ Caution : Fire**

- The equipment uses Diesel Oil as a fuel. When refueling, always stop the engine and keep away from fire. Moreover, always wait until the engine cools down before refueling.
- Always wipe any drip of Diesel fuel or lubrication oil. Do not use this equipment when a leak is found. Repair the equipment before use.
- Temperature around muffler and exhaust can get extremely high. Keep any inflammable items (such as fuel, gas, paint, etc.) away from the equipment.
- Keep any inflammable items and easily burning items away from the place in welding, because welding splashes spatters.
- Always operate this equipment on flat surface and, at least 1 meter away from any objects (wall, box, etc.).
- Do not connect AC output to any indoor wiring.
- Always wait until the equipment cools down, before placing any covering materials for storage.

**⚠ Caution : Burns**

- Do not touch the engine and muffler during operation and immediately after stopping the equipment, for the temperature can reach extremely high.
- When checking engine oil or changing oil, always stop the engine, and wait until the engine cools down. If you open either the oil gauge or the oil plug during operation, hot oil may cause some injury.
- Be sure to wear leather gloves, apron, shoe covers, eye protection glass(es) (mask), safety shoes, safety cap, and long sleeve shirts, because welding splashes spatters.
- Do not open the side door during operation and immediately after stopping the equipment, because some parts/components (flexible tube, resistors, etc.) can reach very high temperature inside the equipment.

**⚠ Caution : Injuries**

- When lifting the equipment, always use a lifting lug. Do not lift the roping lug, for it may cause equipment to drop due to roping lug breaking off.
- When carrying the equipment by trucks, fix it strongly to keep the equipment from sliding.
- Always place the equipment on a flat and stable surface, to keep the equipment from sliding.
- When starting the engine, turn off the connected equipment and set the circuit breaker to OFF position.
- Do not move the equipment during operation.
- When performing equipment check and maintenance, always stop the engine.
- Do not operate the equipment, if the equipment is being modified or if the parts are removed.

■ Location of Warning labels

When the warning labels become unreadable or damaged, place new labels on the appropriate locations, as specified in the following figure.

When ordering the label, use the following part numbers.

- |   |                           |
|---|---------------------------|
| ① Suffocation from exhaust fume (No. 19402-00194) |                           |
| ② Suffocation from welding fume (No. 19402-00195) |                           |
| ③ Electric shock (No. 19402-00193)                |                           |
| ④ Fire (No. 19402-00166)                          |                           |
| ⑤ Injury (No. 19402-00199)                        | ⑧ Burns (No. 19402-00200) |
| ⑥ Injury (No. 19402-00207)                        | ⑨ Burns (No. 19402-00201) |
| ⑦ Injury (No. 19402-00210)                        | ⑩ Burns (No. 19402-00256) |

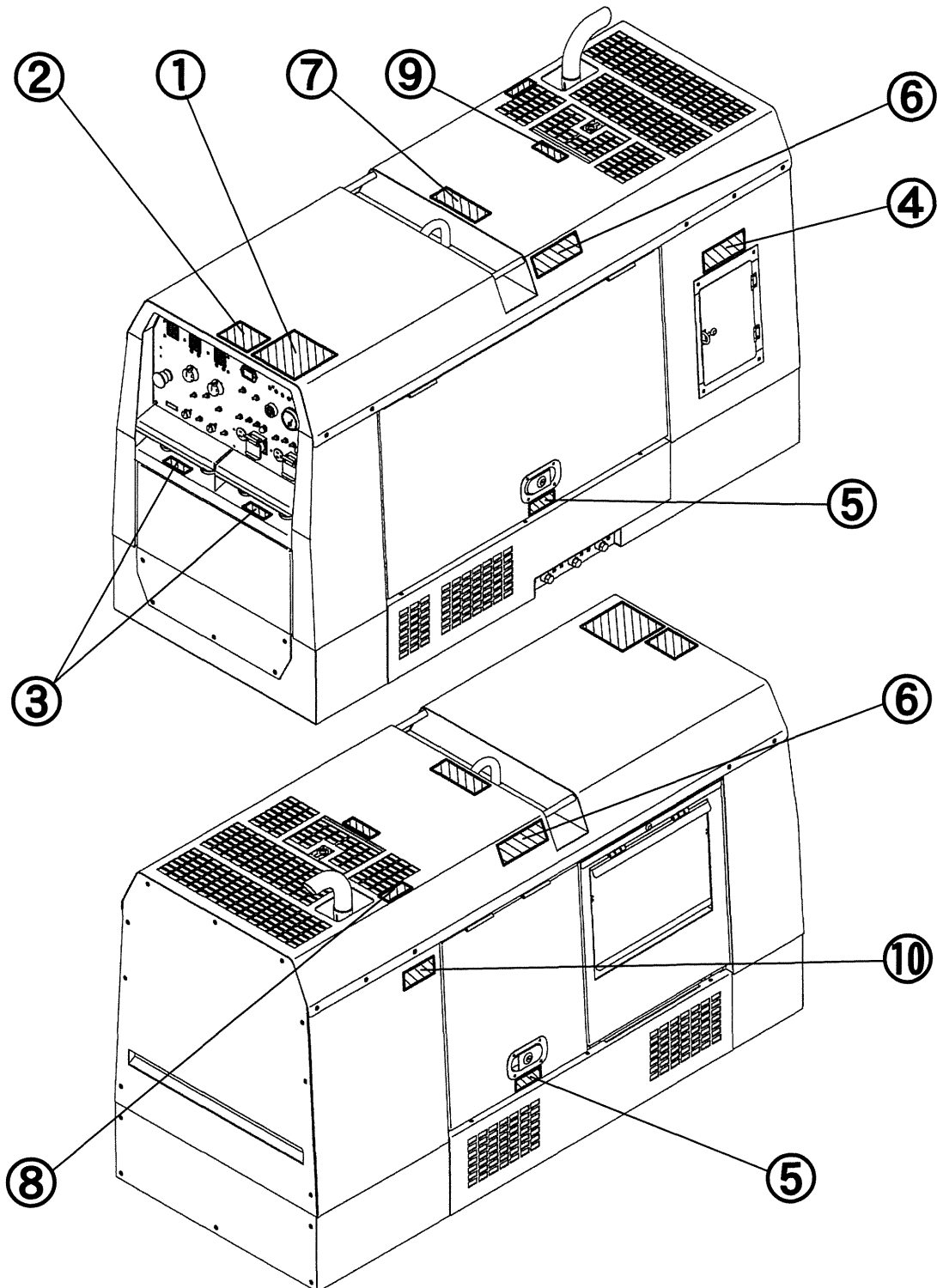

## 2. Specifications

Model		DGW500DM		
Generating Method		Rotating Field		
Welding Generator	OPERATION		SINGLE	DUAL
	CC MODE	Rated Current (A)	480	230
		Rated Voltage (V)	39.2	29.2
		Duty Cycle (%)	60	80
		Current Adj. Range (A)	60 – 500	30 – 280
		Welding Rod ( $\phi$ )	2.6 – 8.0	2.0 – 6.0
		Gouging Rod ( $\phi$ )	3.2 – 9.5	3.2 – 5.0
	CV MODE	Rated Current (A)	480	230
		Rated Voltage (V)	39.0	22.5
		Duty Cycle (%)	60	80
		Voltage Adj. Range (V)	14 – 40	14 – 29
		Welding Wire ( $\phi$ )	0.6 – 2.4	0.6 – 2.0
	Rated Speed ( $\text{min}^{-1}$ )		3000	
No Load Voltage (V)		MAX 85		
AC Generator	Rated Frequency (Hz)		50	
	Rated Speed ( $\text{min}^{-1}$ )		3000	
	Phase		1-Phase	3-Phase
	Rated Voltage (V)		240	415
	Power Factor		1.0	0.8
	Rated Output (kVA)		10.8	15
	Rating		Continuous	
Engine	Model		Kubota V1505	
	Type		Vertical, Water-Cooled 4-Cycle Diesel Engine	
	Displacement (L)		1.498	
	Rated Output ( $\text{kW}/\text{min}^{-1}$ )		29.0 / 3600 (Gross Intermittent)	
	Fuel		ASTM No.2 Diesel Fuel or Equivalent	
	Lubricant Oil		API Class CD or Higher	
	Lubrication Oil Volume (L)		6.0 (Effective 2.0)	
	Cooling Water Volume (L)		5.6 (Sub Tank Capacity 0.8 L included)	
	Starting Method		Starter Motor	
Battery		75D31R		
Fuel Tank Capacity (L)		63		
Dimension	Length (mm)		1680	
	Width (mm)		700	
	Height (mm)		950	
Dry Weight (kg)		613		

## 3. Use

- CC Power for Stick Welding
- CV Power for Wire Feeder
- Arc Gouging
- Power Source for Lights, Electric Tools and Home Appliances

### **⚠ Caution : Damage to the equipment or other properties**

- The equipment is designed for the above purposes only. Do not use it for the other purpose. When it will be used for the equipment with the microcomputers control or for the ultra-precision devices, the load may be malfunctioned.
- Whenever connecting to use medical equipment or appliances, be sure to consult with the medical equipment company, doctor or hospital personnel.

**4. Parts**

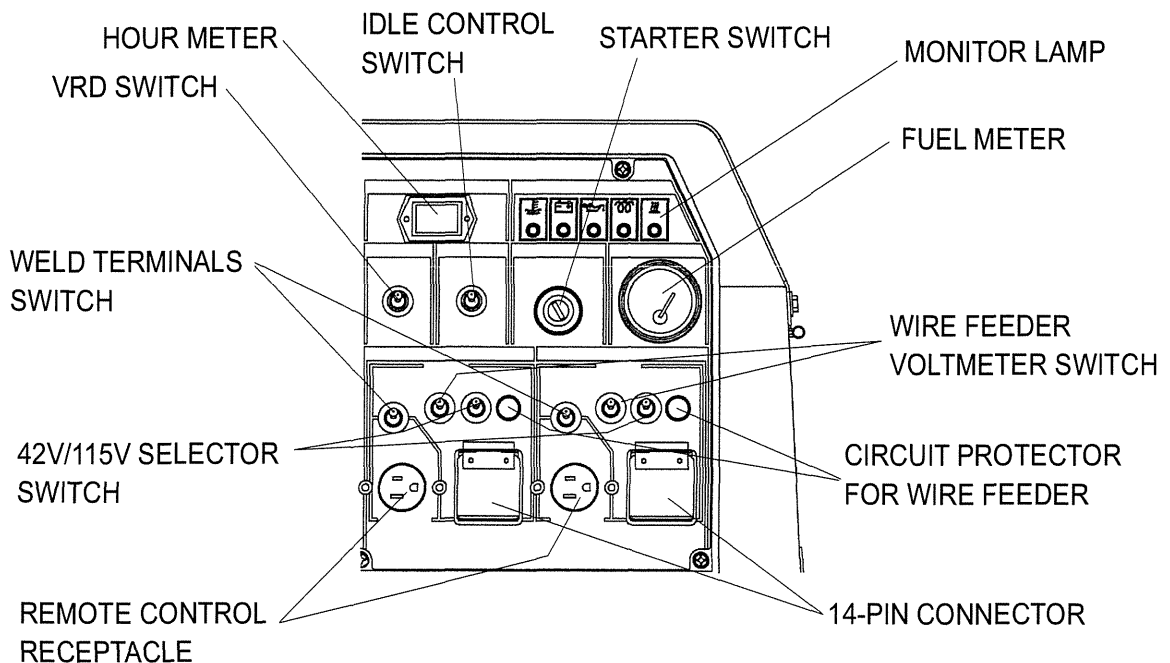
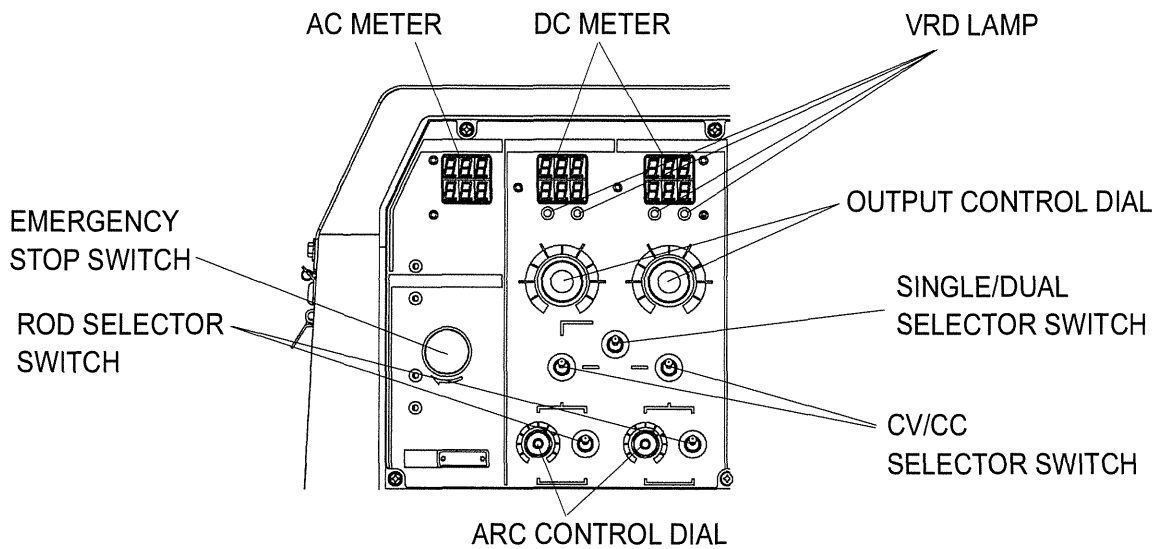
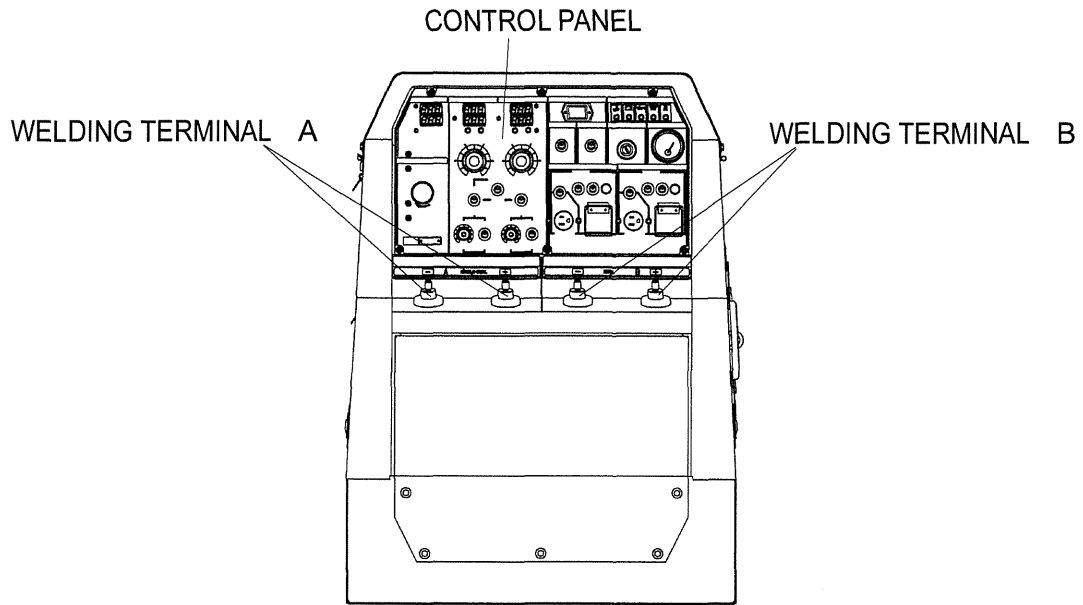



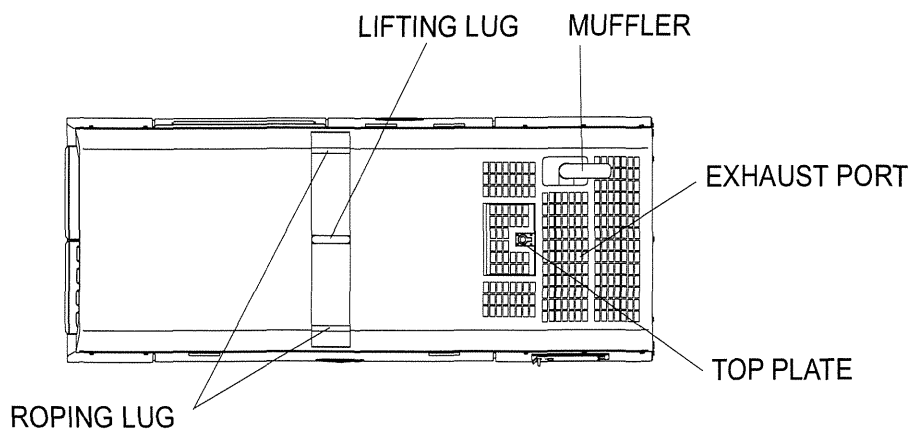
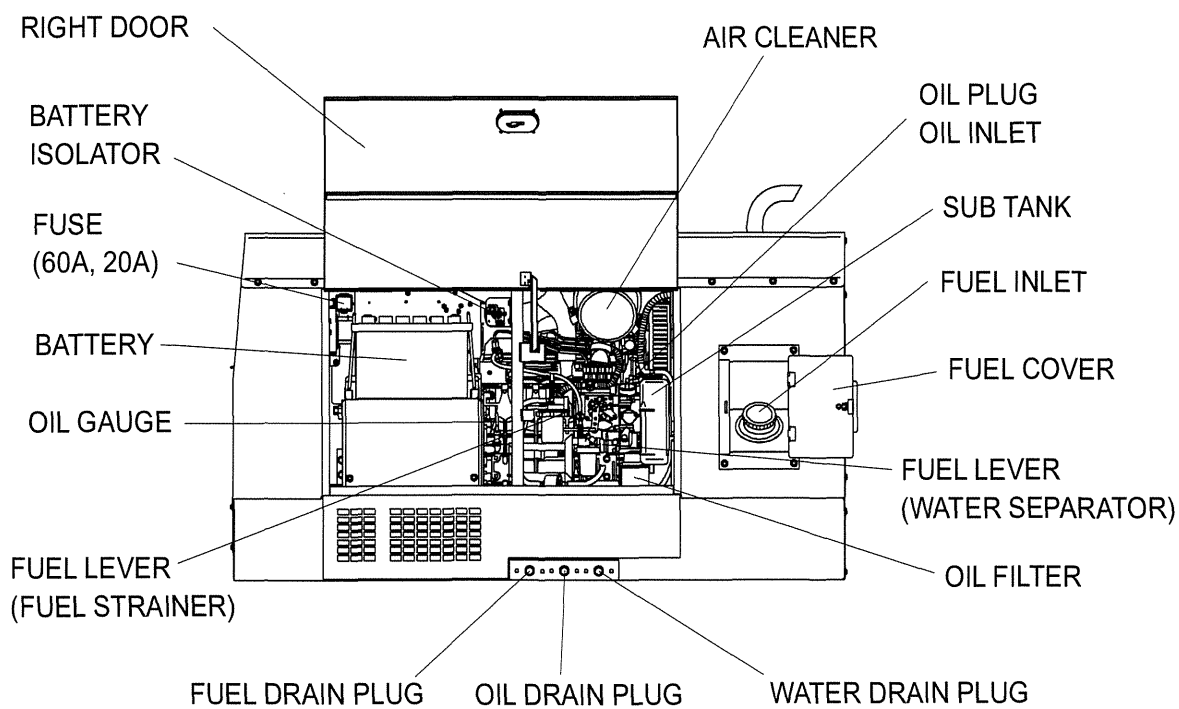
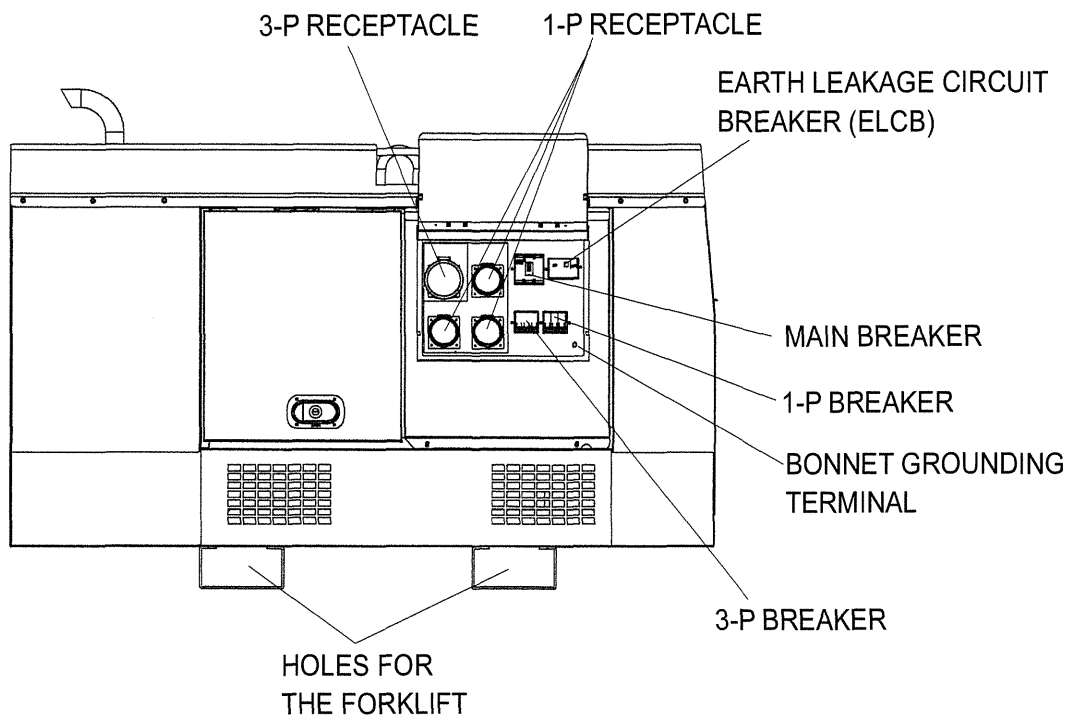

## 5. Equipment

### 5-1. Welding Output Control

#### (1) CV/CC

The equipment incorporates CV (Constant Voltage) and CC (Constant Current) characteristic feature.

Connecting a wire feeder and then turning the CC/CV Selector Switch to [CV-WIRE], semi-automatic welding such as MIG, MAG, SS, etc. is available to perform.

Connecting the welding cables and then turning the CV/CC Selector Switch to [CC-STICK, GOUGING], stick welding or arc gouging is available to perform.

When the CV/CC Selector Switch is positioned at [CV-WIRE], the current from the terminals becomes Constant Voltage Characteristic. Therefore, you have to adjust voltage by the Output Control Dial.

When the CV/CC Selector Switch is positioned at [CC-STICK, GOUGING], the current from the terminals is Constant Current Characteristic. Therefore, you have to adjust current by Output Control Dial.

#### (2) Welding Output Pre-Set

The equipment incorporates Welding Output Pre-Set feature.

When the CV/CC Selector Switch is positioned at [CV-WIRE], CV Output voltage can be Pre-Set by the Output Control Dial

When the CV/CC Selector Switch is positioned at [CC-STICK, GOUGING], CC Output current can be Pre-Set by the Output Control Dial.

<Caution>

- The applicable remote controller with 2-Pin plug has an Output control dial which can be adjusted the output current in the remote area prior to the dial on the machine.

#### (3) ARC CONTROL (for CC mode)

The equipment incorporates Arc Control feature.

Arc Control can be adjusted by turning the Arc Control Dial for suitable arc performance.

Stable (Mild) welding arc can be obtained with Arc Control Dial negative(－) dial side and Strong (Crisp) welding arc can be obtained with Arc Control Dial positive(＋) dial side.

#### (4) ROD SELECTOR (for CC mode)

The equipment incorporates Rod Selector feature.

When the CV/CC Selector Switch is positioned at [CC-STICK, GOUGING], the welding characteristics can be switched by changing Rod Selector Switch. [CELLULOSE] mode is suitable for the Cellulose Rods and [OTHERS] mode is suitable for the Gouging Rods and ordinal rods except cellulose.

## 5-2. VRD

The equipment incorporates VRD (Voltage Reduction Device) feature, for the purpose of protecting an operator from electric shock with welding current. When the VRD Switch is turned to [ON], the voltage changes to 35V or lower during no welding period.

The equipment is incorporated in monitoring function of VRD.

When the VRD Switch is turned to [ON], Green VRD Lamp will be automatically turned on at [BELOW 35V] side.

When the Red VRD lamp will be turned on at [AT OR ABOVE 35V] side, the welding voltage is exceeded more than 35V accidentally or while the VRD switch is [OFF].

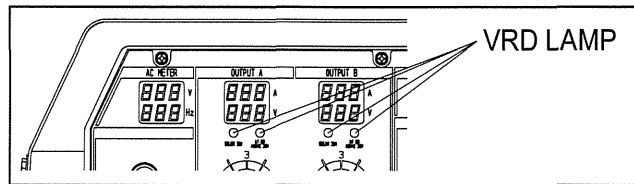

## 5-3. Output Remote Control

The equipment incorporates Output Remote Control feature.

### (1) 14-Pin Connector (Wire Feeder Control)

Wire Feeder Control operation is available by connecting the Wire Feeder to the 14-Pin Connector

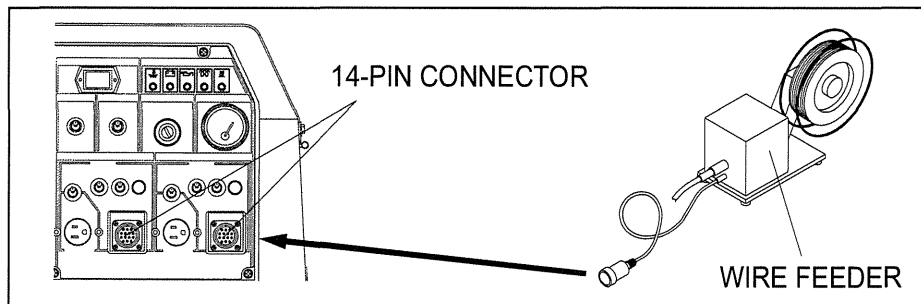

### (2) Weld Terminals Switch

Wire Feeder Control operation is available by turning the Weld Terminals Switch to [W.F.REMOTE]

When the Weld Terminals Switch to [WELD TERMINAL ON], the welding voltage is always supplied at machine's welding terminal.

When the Weld Terminals Switch to [W.F.REMOTE], the welding voltage will be supplied at machine's welding terminal by pressing the wire feeder torch trigger.

### (3) Wire Feeder Voltmeter Selector

Selecting Wire Feeder Voltmeter Switch can be switched the voltmeter indication polarity which is equipped on the wire feeder unit.

### (4) 42V / 115V Selector

Selecting 42V / 115V Selector Switch can be switching the supply voltage for the required output voltage based on the wire feeder specification.

### (5) Circuit Protector for Wire Feeder

When the over current (more than 5A) is flown into 14-Pin Connector for wire feeder, the Circuit Protector will be activated to shut off the current.

<Caution>

- Resolve the over current issue to proceed the necessary maintenance when the Circuit Protector was activated, with reset the trip button.

#### (6) Remote Control (Option)

Remote Control operation is available by connecting the remote control box. You can adjust the welding current (in CC condition) or welding voltage (in CV condition) in the remote area from the machine.

#### ■ Remote Control Box Connection

- ① Insert the plug of the remote control box into the remote control receptacle.

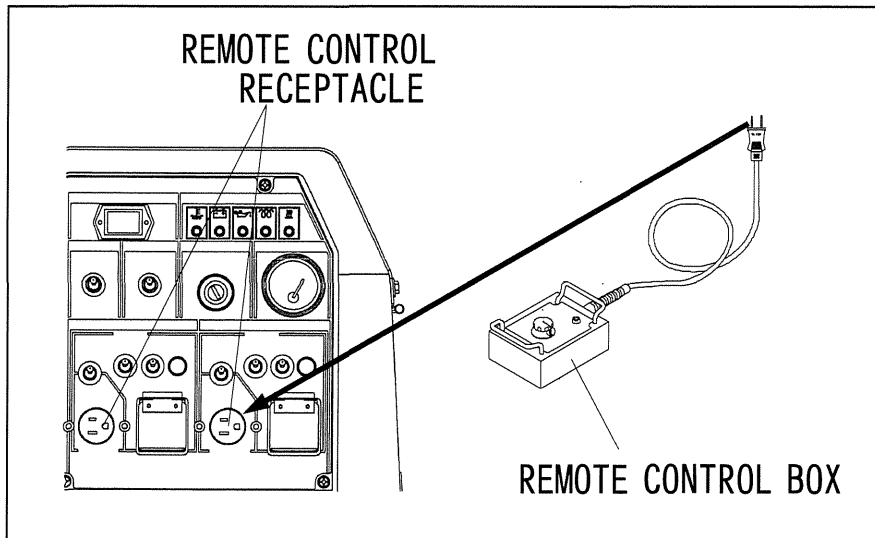

<Caution>

- Never connect the other loads additionally than the remote control box.
- In the case the extension cable reel is installing the breaker, use the equipment to have turned the breaker ON.

#### 5-4. Meter

The equipment incorporates digital meters, voltage & amperage of welding output and also 3-Phase Voltage & frequency of AC output.

#### (1) DC Ampere Meter · Volt Meter

Each meter displays welding voltage and amperage in Side A or Side B terminals. When the SINGLE /DUAL Selector Switch is positioned at [SINGLE], the meters do not display the amperage or the voltage in Side B terminals.

<Caution>

- While operating at no-load, if the CV/CC Selector Switch is set as [CV-WIRE], DC Volt Meter is indicating desired voltage by Output Control Dial.  
(There is no display at DC Ampere Meter while no-load.)
- While operating at no-load, if the CV/CC Selector Switch is set as [CC-STICK, GOUGING], DC Ampere Meter is indicating desired amperage by Output Control Dial.  
(There is no display at DC Volt Meter while no-load.)
- During actual welding work, both DC Volt Meter · Ampere Meter displays actual output. Both displays will be back to the pre-set value after counting about 8seconds with blinking dot on the DC Volt meter.

## (2) AC Meter

The meter displays the 3-Phase voltage (U-V) and the frequency in AC output.

## 5-5. Monitor Lamp

The equipment is incorporated in monitoring function of WATER TEMP, BATTERY CHARGING, OIL PRESSURE, OVERHEAT.

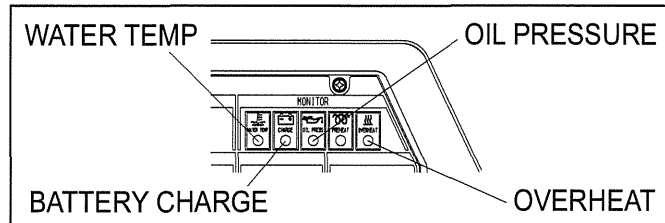

Under normal condition, when the starter switch changes from [STOP] to [RUN], all the lamps of BATTERY CHARGING, OIL PRESSURE and OVERHEAT turn ON. When the engine starts, all the lamps turn OFF. When abnormality is detected on other than OVERHEAT, the corresponding monitor lamp will flash, and the engine automatically shutoff.

When the automatic shutoff is engaged, turn the starter switch to [STOP] position once, and then restart the engine. In the event the automatic shutoff is engaged next time, check which lamp turns ON or OFF and point out where is the abnormality.

## (1) Coolant/Water Temperature Monitor Lamp

### ⚠ Danger: Injuries

- Close all doors and place locks during operating this equipment, to avoid injuries by unintentionally touching cooling fan and fan belt.

### ⚠ Danger: Burns

- Do not open the radiator cap while operating this equipment or immediately after stopping the equipment, to avoid sustaining burns from hot vapor.

### ⚠ Caution: Burns

- Do not touch the engine and muffler during operation and immediately after stopping the equipment, for the temperature can reach extremely high.

When the water temperature rises abnormally, the coolant/water temperature monitor lamp will flash, and the automatic shutoff will be engaged.

When this occurs, check the coolant/water reservoir tank, and replenish if needed. (Refer to 『6-2. Checking coolant/water』 )

If the water level is normal, there may be a possibility of overloading. Always use the equipment within the rated duty cycle and output power.

## (2) Battery Charge Monitor Lamp

When the battery turns unable to be charged during operation, the battery charge monitor lamp will flash and the automatic shutoff will be engaged.

In the event this occurs, consult with the authorized distributor or our engineering section.

<Caution>

- The battery charge monitor cannot detect the degradation of the battery nor the battery fluid level. Check the battery fluid level periodically.  
(Refer to 『6-5. Checking Battery』 )

### (3) Oil Pressure Monitor Lamp

#### **Danger : Injuries**

- Close all doors and place locks during operating this equipment, to avoid injuries by unintentionally touching cooling fan and fan belt.

#### **Caution : Burns**

- Do not touch the engine and muffler during operation and immediately after stopping the equipment, for the temperature can reach extremely high.
- When checking engine oil, always stop the engine, and wait until the engine cools down. If you open either the oil gauge or the oil filter cap during operation, hot oil may cause some injury.

When the engine oil pressure drops during operation, the oil pressure monitor lamp will flash, and the automatic shutoff will be engaged.

When this occurs, check the engine oil level, and replenish to the maximum level if needed.

<Caution>

- The engine oil pressure monitor cannot detect the degradation of engine oil itself. Please check the engine oil periodically, and change if needed.  
(Refer to 『11. Checking and Maintenance』 )
- Check the fuse next, when the abnormality, other than WATER TEMP, BATTERY CHARGED OR OIL PRESSURE is detected. If the fuse is burned out, consult with our authorized distributor or our engineering section, because there may be an abnormality of electric/electronic parts or wiring and repairing may be required.

### (4) Overheat Monitor Lamp

OVERHEAT monitor lamp may flash in the case the machine is used excessively over the duty cycle or over load.

When the OVERHEAT monitor lamp is blinking, this equipment cuts the out put off.

When this overheat occurs, there may be a possibility of overloading. Always use the equipment within the rated duty cycle and output power.

<Caution>

- There may be a case that the lamp will not flash, depending on the welding type or the weather condition.

## 5-6. Earth Leakage Relay

### ⚠ Danger : Electric Shock

- Ground every grounding terminal to the earth as set out in the manual. If even one of all is unconnected by mistake or accident, it will be much more dangerous for human body than the NO RELAY case, because leaking current inevitably goes through the body.
- Even though all the terminals of the loads have been grounded to the earth, the bonnet (canopy) grounding terminal should be grounded to the earth.
- Grounding should be made after the engine is stopped.
- Whenever the earth leakage relay has activated, you should always repair the leaking place first of all.

The equipment is provided with the earth leakage relay in the Circuit Breaker to detect any leakage arisen due to the troubles as insulation failure of the load while the generator is running. And cutting off the circuit for protection against any accident such as electrical shock resulting from the trouble.

The specifications of the earth leakage relay:

- Rated Sensitive Current: 30mA (or below)  
(Grounding resistance: 500Ω or below)

### (1) Grounding Work

The qualified electrician should perform the grounding work of the following 2 points(500Ω or below).

- The Outer Bonnet of this equipment (bonnet grounding terminal)
- The Outer Bonnet of the load

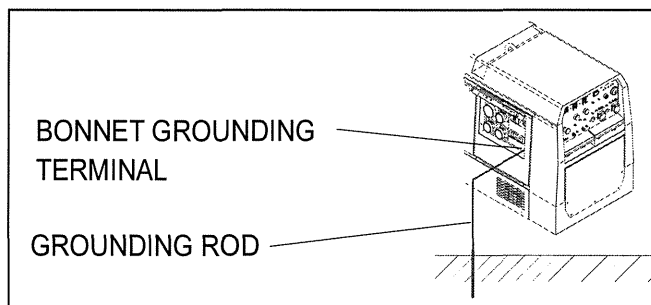

<Caution>

- In the event you cannot ground the generator to the earth, consult with the authorized distributor or our engineering section.

### (2) Operation Check

Before operating the equipment, check always if the device can work duly as shown in the following procedure.

- ① Start engine after turning the Idle Control Switch to [HIGH].
- ② Turn (Push-up) the ELCB (lever) to [ON] position.
- ③ Push the test button. The device is found to be normal when the ELCB (lever) turns to [OFF].

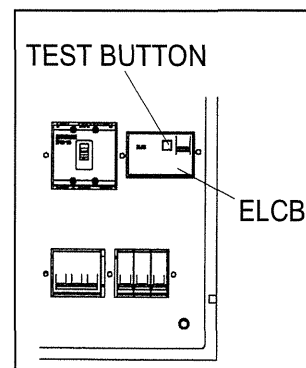

- In the event you cannot complete all steps in the above procedure to the end, the device is out of order. Consult with our authorized distributor or our engineering section to repair.

### (3) The Earth Leakage Relay has activated

#### **⚠ Caution : Electric Shock / Injuries**

- Be sure to disconnect all the loads to the equipment when turning the breakers ON again, after the earth leakage relay has activated.

When the earth leakage relay has activated, the ELCB (lever) turns to [OFF]. In the case, stop the engine promptly and find the leakage point to repair. After repairing leakage point(s), return (push up) the ELCB (lever) to [ON].

### 5-7. Auto Idle Feature

The Auto Idle feature is to set the engine speed low automatically (in about 8 seconds) for the purpose of reducing noise and fuel consumption, whenever no welding operation or electric supply is performed.

In the case of using the Auto Idle feature, turn the Idle Control Switch to [AUTO]. By the condition, the engine automatically moves to high speed, whenever welding operation or electric supply starts.

#### **⚠ Caution : Damage to the equipment or other properties**

- Turn always the Idle Control Switch to [HIGH], when the load is incorporated with any magnet switch.

<Caution>

- When the load of less than 0.5A is connected to use, the Auto Idle feature does not function sometimes. Therefore, turn the switch to [HIGH].
- When welding operation or electric supply performs alternately or intermittently, turn the switch to [HIGH].

### 5-8. Emergency Stop Switch

The Emergency Stop Switch is used to stop the engine in emergency. By pushing the switch, the engine stops. Be sure to restore the Starter Switch to [STOP] and reset the Emergency Stop Switch, turning clockwise after using the switch.

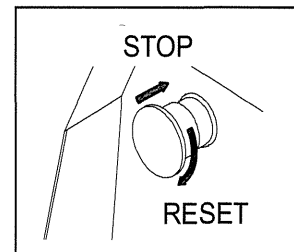

### 5-9. Battery Isolator

When turning the Battery Isolator Switch to [OFF] position, the engine electric circuit does not get battery power.

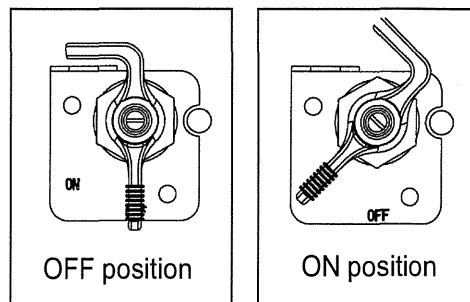

<Caution>

- Do not turn the Battery Isolator position while in operation, it may cause the serious damage on the unit.



**6. Initialization and Pre-check**

**⚠ Caution : Fire · Burns · Injuries**

- When checking engine, always stop the engine, and keep away from fire. Wait until the engine cools down, before performing any checks.

**6-1. Checking Engine Oil**

When checking for engine oil, be sure to keep the equipment leveled, and insert the oil gauge all the way in.

Prior to starting the equipment, make sure to fill the engine oil to the UPPER line through the oil inlet.

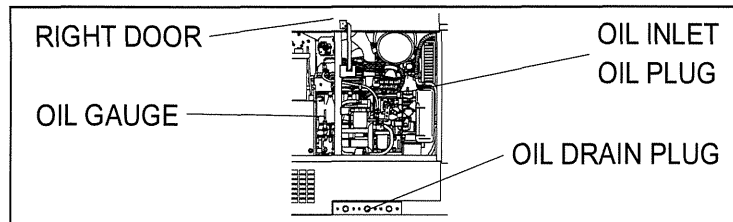

<Caution>

- If the equipment is not leveled, you cannot obtain accurate oil level. Do not overfill (over UPPER line) the engine oil. The excessive amount of engine oil may damage the engine (inside the cylinders)

- Selecting proper engine oil

<Caution>

- Use the API class CD or higher.

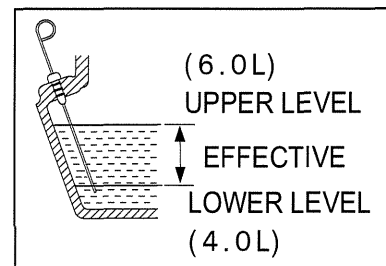

Viscosity and Temperature

Temperature	Over +20°C	+10~+20°C	-10~+40°C
Viscosity	SAE30	SAE20	SAE10W/30

**6-2. Checking Coolant / Water**

**⚠ Danger : Injuries**

- Close all doors and place locks during operating this equipment, to avoid injuries by unintentionally touching cooling fan and fan belt.

**⚠ Danger : Burns**

- Do not open the radiator cap while operating this equipment or immediately after stopping the equipment, to avoid sustaining burns from hot vapor.

**⚠ Caution : Burns**

- Do not touch the engine and muffler during operation and immediately after stopping the equipment, for the temperature can reach extremely high.

Check to see if the coolant/water level is between FULL and LOW levels in the sub tank. If the coolant/water is below the LOW level, fill the tank and the radiator accordingly.

### (1) Filling to the Reservoir Tank

- ① Remove the sub tank cap.
- ② Fill up the sub tank to the FULL level.
- ③ Install the cap back.

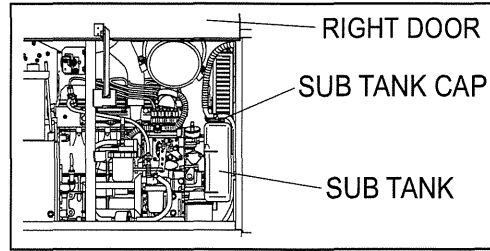

### (2) Filling to the Radiator

- ① Open the top plate.
- ② Remove the radiator cap.
- ③ Fill the radiator up to the top.
- ④ Install the cap back and tighten.
- ⑤ Close the top plate.

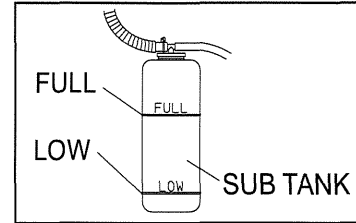

#### <Caution>

- Use Long Life Coolant (LLC), for prevent freeze and rust. (30% mixture LLC is filled when shipped from factory)
- Mixture ratio of the coolant should be 30%-45%, depending on the ambient temperature.
- Replace LLC at every year or 2000 hours.

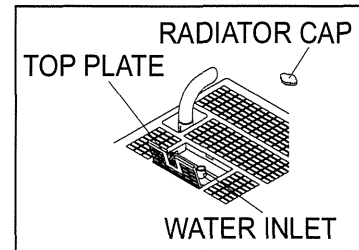

Mixture Ratio (for reference only)

Lowest Ambient Temperature	-15°C	-20°C	-30°C
Mixture Ratio	30%	35%	45%

### 6-3. Checking Fuel

#### **⚠ Caution : Fire**

- Always wipe any drip of fuel. Do not use this equipment when any leak is found. Repair the equipment before use.

Check for the fuel level in the tank. Add if necessary.

#### <Caution>

- Use Diesel fuel, ASTM D975 No.2-D in the event ambient temperature reaches down to -5°C.
- The engine is designed to use either No.1-D or No.2-D Diesel fuel. However, for better economy, use No. 2-D Diesel Fuel whenever possible. At temperatures less than -7°C(20°F ), No.2-D fuel may pose operating problems (see “Cold Weather Operation which follows). At colder temperatures, use No.1-D fuel (if available) or use a “winterized” No.2-D (a blend of No.1-D and No.2-D). This blended fuel is usually called No.2-D also, but can be used in colder temperatures than No.2-D fuel which has not been “winterized”. Check with the services stations operator to be sure you can get the properly blended fuel. Note that Diesel fuel may foam during a fill-up. This can cause the automatic pump nozzle to shut off even though your tank is not full.
- Always use the fuel strainer.
- Fill the fuel tank slightly less than the FULL tank.

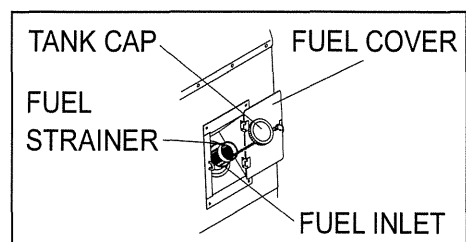

## 6-4. Checking Fuel, Engine Oil and Water Leakage

### **⚠ Caution : Fire**

- Do not use this equipment when a leak is found. Repair the equipment before use.

Be sure to check any leakage for fuel, oil and coolant/water at the hose connections by opening side doors. Whenever checking any fuel leakage, turn the fuel lever [OPEN] and be sure to close the fuel lever after checking.

## 6-5. Checking Battery

### **⚠ Caution : Injuries to eyes and skin**

- Battery fluid contains diluted sulfuric acid. Avoid contact with eyes, skin or clothing.
- If the acid comes to contact, especially with eyes, flush with a lot of water, and contact your physician immediately.

### **⚠ Caution : Explosion**

- Do not use the equipment or charge the battery, in the case the battery fluid level is lower than the LOWER level.
- Battery may emit some combustible gas, so keep it away from fire and sparks.

### **⚠ Caution : Fire**

- Battery may emit some combustible gas, so keep it away from fire and sparks.

- ① Check the fluid level. If the level is near or lower than LOWER level, add distilled water until the fluid level reaches UPPER level.
- ② Make sure that the battery cables are firmly secured to the posts. Tighten the clamps if necessary.

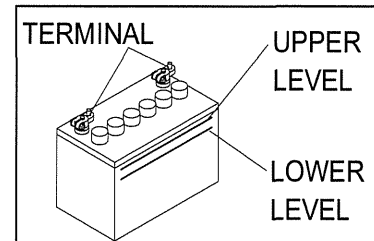

<Caution>

- Make sure to turn to [OFF] the Battery Isolator Switch before attempting to maintain the battery terminal.
- Check the hydrometer of the battery fluid. If it falls below 1.23, the battery requires recharging. Please consult with our authorized distributor or our engineering section.

### ■ Replacing battery

- ① Turn the Battery Isolator Switch to [OFF]
- ② Remove the clamp and cable from negative [-] post on the battery. (Remove always negative side first)
- ③ Remove the hold-down clamp from the battery.
- ④ Remove the clamp and cable from positive [+] post on the battery.
- ⑤ Remove the battery from the seat.

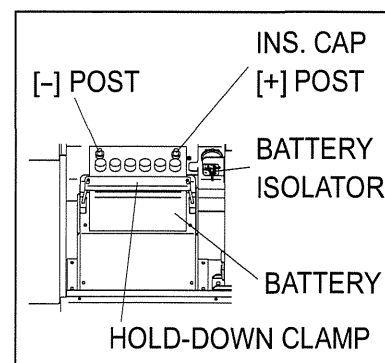

- ※ Reinstall a new battery in the reverse order.  
(Install always the cable to the positive [+] post in the new battery first.)

<Caution>

- Use the following battery.  
75D31R

## 7. Operation

### ⚠ Danger : Suffocation from exhaust fume

- Exhaust fume from the engine contains many elements harmful to human. Do not operate this equipment in poorly ventilated area, such as inside a room or in a tunnel.

### ⚠ Caution : Suffocation from exhaust fume

- Do not point the exhaust fume toward pedestrians or building.

### ⚠ Caution : Fire

- Temperature around muffler and exhaust can get extremely high. Keep any inflammable items (such as fuel, gas, paint, etc.) away from the equipment.
- Always operate this equipment on flat surface and, at least 1 meter away from any objects (wall, box, etc.)

### ⚠ Caution : Injuries

- Always place the equipment on a flat and stable surface, to keep the equipment from sliding. Be sure to lock the wheels for the wheeled models.
- Before starting the engine, be sure to disconnect the loads and set the breakers (Main, 1-P, 3-P) to [OFF] position.

### 7-1. Starting

- ① Turn the breakers (Main, 3-P, 1-P) to [OFF]
- ② Turn the every Fuel lever (on Fuel Strainer and Water Separator) to [OPEN].
- ③ Turn the Battery Isolator Switch to [ON]
- ④ Turn the Idle Control Switch to [AUTO].
- ⑤ Ensure the Emergency Stop Switch is positioned to release.
- ⑥ When the temperature is below  $-5^{\circ}\text{C}$ , turn and keep the Starter switch to PREHEAT until the preheat lamp turns off (about 5 seconds).
- ⑦ Turn the Starter Switch to [START] and then the engine starts by the starter motor.
- ⑧ Release the Starter Switch, as soon as the engine has started.
- ⑨ Keep the engine idle for about 5 minutes.

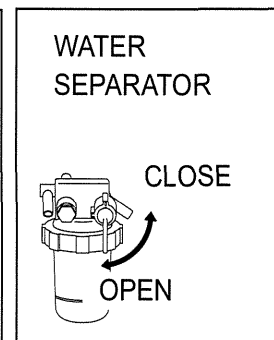
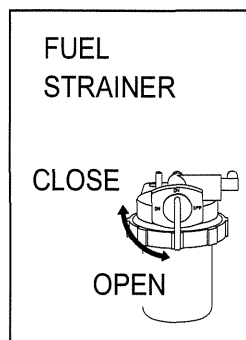
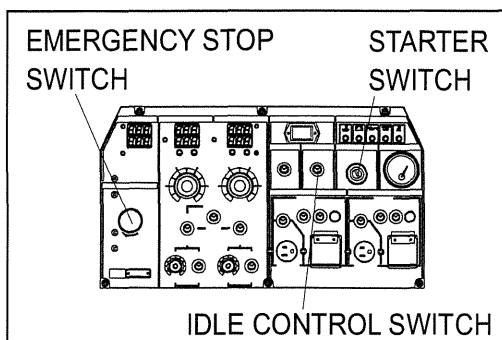
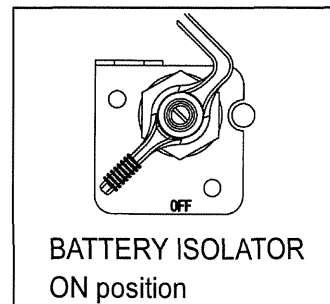
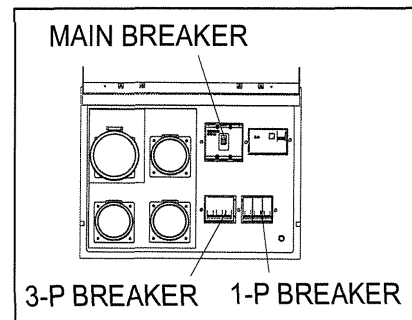

<Caution>

- Do not drive the starter motor for more than 15 seconds successively.
- If you need to restart, wait for 30 seconds or more before retry.
- Once the engine has started, never turn the starter switch to [START].

■ Restart after stopping due to fuel shortage

This equipment is incorporated in automatic vacuuming air feature. Therefore, even though the engine stops due to running out of fuel, you can restart the engine easily by the following steps.

- ① Turn the Starter Switch to [STOP].
- ② Fill the fuel.
- ③ Turn the Idle Control Switch to [AUTO].
- ④ Turn the Starter Switch to [START] and drive the starter motor for about 10 seconds.
- ⑤ Release the Starter Switch, as promptly as the engine started.
- ⑥ Wait for about 1 minute to vacuum the air out. The engine speed becomes stable when the air is extracted.

<Caution>

- Never turn the engine HIGH speed or connect the loads until the air is extracted completely (the engine speed becomes stable)

**7-2. Stopping**

- ① Turn (Push-down) the breakers (Main, 3-P, 1-P) to [OFF].
- ② Turn the Idle Control Switch to [AUTO].
- ③ Keep the engine idle (cooling down) for about 5 minutes.
- ④ Turn the Starter Switch to [STOP].
- ⑤ After the engine has stopped, turn the every Fuel Lever to [CLOSE].
- ⑥ Turn the Battery Isolator Switch to [OFF] position.

<Caution>

- When the engine does not stop in spite of turning the Starter switch to [STOP], Turn the Fuel Lever on Fuel Strainer or Water Separator to [CLOSE], then the engine will stop in a few minutes.  
In this case, be sure to consult with our authorized distributor or our engineering section and ask to repair.
- Do not attempt to turn to [STOP] position while actual welding or utilizing AC power source, it may cause the serious damage on the unit.

**7-3. Emergency Stopping**

The Emergency Stop feature is incorporated in the equipment.  
Push the Emergency Stop Switch in case of an emergency or equipment abnormality during operation.

- ① Push the Emergency Stop Switch to stop engine in an emergency case.

<Caution>

- Be sure to return the Starter Switch to [STOP] after the engine stops.
- Never hit the Emergency Stop Switch by any tool such as a hammer.
- Never use the Emergency Stop Switch except an emergency case.
- Turn the Fuel Lever on Fuel Strainer or Water Separator to [CLOSE] to stop in the case the Emergency Stop Switch does not function.

- ② Turn the Emergency Stop Switch to arrow mark (clockwise) to release the feature.

<Caution>

- Be sure to re-start the engine after releasing the Emergency Stop feature.
- The engine does not start again though the starter motor is running, without releasing the emergency stop feature.

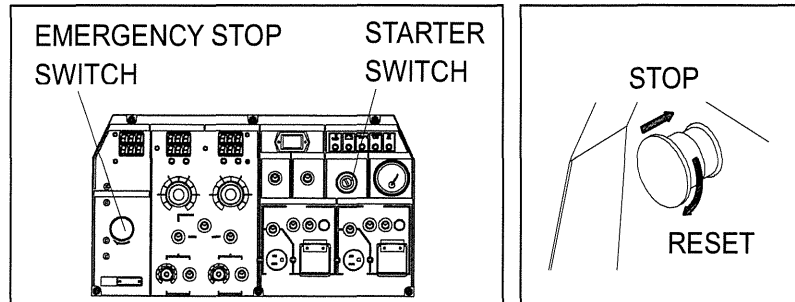

## 8. Welding Operation

### 8-1. Selection – Welding Cable

Select the cable with proper gauge, based on the allowable amperage and the length, per the table shown below.

The welding capacity is to reduce if the small gauge cable is used.

<Caution>

- Welding cables should be used unstrained. When the welding cables are used in swirl, the welding capacity is to reduce.

Size of Cable (Unit: mm<sup>2</sup>)

Return Length \ Welding Current	20m	30m	40m	60m	80m	100m
500A	38	60	80	125	200	200
450A	38	60	80	100	150	200
400A	38	50	60	100	125	200
350A	30	50	60	80	125	150
300A	30	38	50	80	100	125
250A	22	30	38	60	80	100
200A	22	30	30	50	60	80
150A	22	22	22	38	50	60
100A	22	22	22	30	30	38

### 8-2. Polarity

There are two welding output terminals, 『+』 and 『-』 .

Select the polarity according to the operation, referring to the table below.

<Caution>

- Follow the instruction of the welding rods, the polarity of which is specified.

**(1) Welding Rod (include Gouging Rod)**

	Application	Connection
Normal Polarity	Generals Welding, such as Construction	Plus to the Earth (Material) Minus to holder (Rod)
Reverse Polarity	Thin Plate, Build-Up Welding, Stainless Steel , Gouging	Plus to holder (Rod) Minus to the Earth (Material)

**(2) Semi-automatic wire feeder**

	Application	Connection
Normal Polarity	Self shield Weld (Small Diameter)	Plus to the Earth (Material) Minus to Torch (Wire)
Reverse Polarity	MIG, MAG Welding Self-Shield (Big Diameter)	Plus to Torch (Wire) Minus to the Earth (Material)

**8-3. Connection – Welding Cable**

**⚠ Danger : Electric Shock**

- Before connecting or disconnecting a welding cable from welding output terminals, stop the engine, and remove the engine key. A person performing should always keep the key.

- ① Stop the engine.
- ② Connect a welding cable to a crimping terminal, a welding rod holder (Wire Feeder) and a material holder.
- ③ After connecting cables, be sure to close output terminal covers.

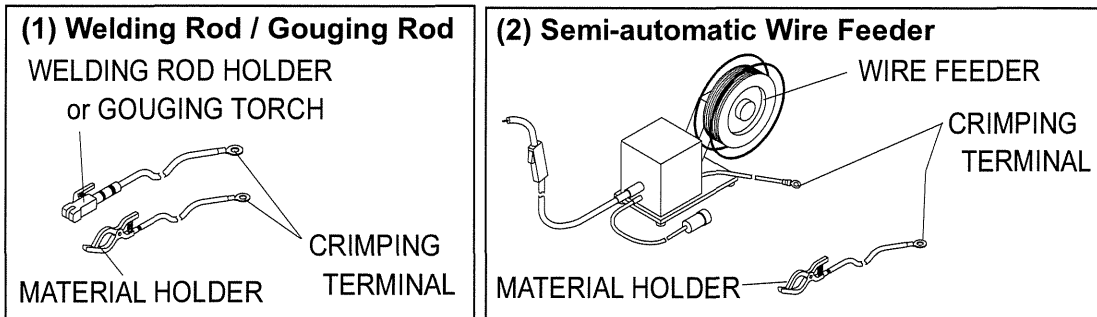

(1) Welding Rod / Gouging Rod		(2) Semi-automatic Wire Feeder	
Single	Dual	Single	Dual
Welding Rod φ 2.6 – φ 8.0	Welding Rod φ 2.0 – φ 6.0	Welding Wire MIG/MAG : φ 0.6 – φ 1.6 Self-Shield : φ 0.9 – φ 2.4	Welding Wire MIG/MAG : φ 0.6 – φ 1.2 Self-Shield : φ 0.9 – φ 2.0
Gouging Rod φ 3.2 – φ 9.5	Gouging Rod φ 3.2 – φ 5.0		
Welding Terminal A	Welding Terminal A & B	Welding Terminal A	Welding Terminal A & B

<Caution>

- Be sure to crimp a crimping terminal to a cable and connect the cable to welding output terminal. Otherwise, welding output terminals may burn out by the heat caused by insufficient connections.
- Do not use a cable without a crimping terminal. If you use the cable, the insulation is peeled off partly, to bind to an output terminal, the output terminal may burn out by the heat caused by insufficient connections and also a bare part of the cable may touch the bonnet to short-circuit.

### 8-4. Duty Cycle

Duty cycle is the percentage of time the load is being applied in a 10 minutes period. For example, a 60% duty cycle represents 6 minutes of load and 4 minutes of no load in a 10 minutes period.

<Caution>

- The equipment may be damaged due to overheat, if welding more than duty cycle.

### 8-5. Welding

#### ⚠ Caution : Suffocation from welding fume

- Be sure to wear a fume proof mask in operation, because welding fume contains poisonous gas and dust. Pay attention to the airflow direction and sufficient ventilation also in order to prevent from inhaling the fume.

#### ⚠ Caution : Injuries to eyes and skin

- Be sure to wear spark protection glass(es)(Refer to the table below), long-sleeve shirts, gloves, etc. in order to protect eyes and skin from harmful spark in welding.

Standard for Spark Protection Glass (Japan Industrial Standard)

No.	7	8	9	10	11	12	13	14
Welding Current (A)	30-75		76-200			201-400		400—

#### ⚠ Caution : Fire

- Keep any inflammable items and easily burning items away from the place in welding, because welding splashes spatters.

#### ⚠ Caution : Burns

- Be sure to wear leather gloves, apron, shoe covers, eye protection glass(es)(mask), safety shoes, safety cap and long sleeve shirts, because welding splashes spatters.

2 persons can weld simultaneously.

Each person can adjust the welding output individually.

The output adjustable range by the Output Control Dial, depends on the position each of the SINGLE/DUAL, CV/CC Selector switch.

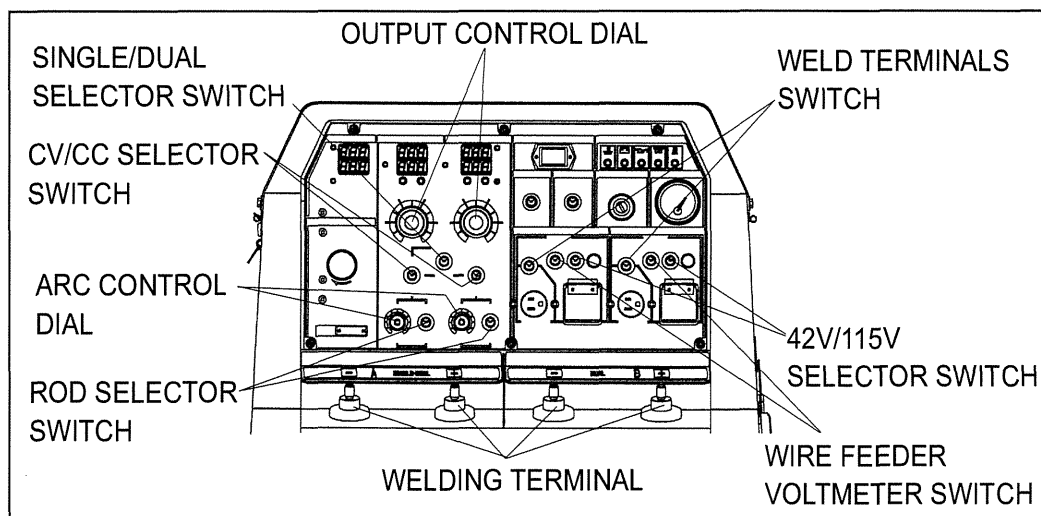



### (1) Welding Rod (include Gouging Rod)

- ① Turn the Weld Terminals Switch to [WELD TERMINALS ON].
- ② Turn the SINGLE/DUAL Selector Switch to [SINGLE] or [DUAL], according to the operation.
- ③ Turn the CV/CC Selector Switch to [CC-STICK, GOUGING].
- ④ Turn the Rod Selector Switch to [CELLULOSE] on cellulose rod welding or to [OTHERS] on gouging or ordinal welding rods except cellulose rod.
- ⑤ Set the current amperage by the Output Control Dial.
- ⑥ Adjust the arc-strike current by turning the Arc Control Dial

### (2) Semi-Automatic Wire Feeder (Weld Terminal)

#### ■ While not using 14-Pin Connector

- ① Turn the Weld Terminals Switch to [WELD TERMINALS ON].
- ② Turn the SINGLE/DUAL Selector Switch to [SINGLE] or [DUAL], according to the operation.
- ③ Turn the CV/CC Selector Switch to [CV-WIRE].
- ④ Set the voltage by the Output Control Dial.

#### ■ While using 14-Pin Connector

- ① Turn the 42V/115V Selector Switch to [42V] or [115V], according to the applicable Wire Feeder.
- ② Connect the Wire Feeder plug into 14-Pin Connector.
- ③ Turn the Weld Terminals Switch to [W.F.REMOTE (WELD TERMINAL OFF)]
- ④ Synchronize the polarity of unit with Wire Feeder display by selecting Wire Feeder Voltmeter Switch.
- ⑤ Turn the SINGLE/DUAL Selector Switch to [SINGLE] or [DUAL], according to the operation.
- ⑥ Turn the CV/CC Selector Switch to [CV-WIRE].
- ⑦ Set the voltage by the Output Control Dial.

#### <Caution>

- The wire feeder will not work properly if the 42V/115V Selector Switch is selected incorrectly compare to the wire feeder rated voltage.

## 9. Generator Operation

### 9-1. Output Range

#### (1) 3-Phase 415V Output Receptacle

Maximum output from the receptacle is 15KVA.

#### (2) 1-Phase 240V Output Receptacles

1-Phase 240V Output is available through 3 receptacle sets. Maximum output is 10.8kVA for 3 receptacle sets.

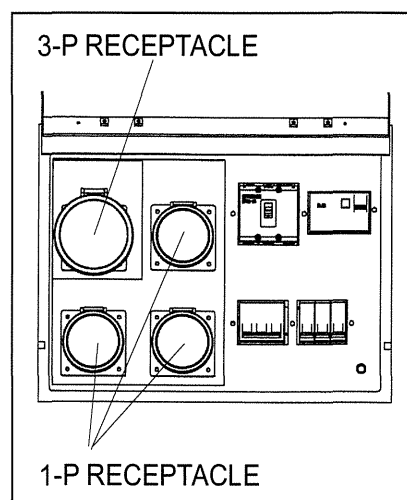

## 9-2. Output Limitation

Please refer to the following table, because electric tools and home appliances cannot be judged only by the rated output or the power consumption due to the efficiency and character of the components.

Applicable Load (For reference purpose only)

Loads	Capacity (kW)		
	1-Phase 240 V		3-Phase 415 V
	Receptacle 1 set	Receptacle 3 set use	Receptacle
Electric Bulb, Heater, etc.	3.6	10.8	---
electric Tools, etc (Series Motor),	1.8	5.4	---
Mercury Bulb (High Power Factor Type)	1.4	4.3	---
Submersible Pump, Compressor, etc (Induction Motor)	1.4	4.3	6.0

- ※ Series Motor : Motor with brush
- ※ Induction Motor : Brushless Motor
- ※ The value described is 『OUTPUT』 for Induction Motor loads and 『POWER CONSUMPTION』 for the other equipment.

### <Caution>

- Be sure to use the frequency designated in the equipment incorporated in mercury bulb or induction motor.
- The load incorporated in motor may require bigger power than the rated power consumption. Therefore, consult with our authorized distributor or our engineering section to clarify.
- When connecting to use 2 or more sets, start the load one by one, not to start them simultaneously.
- When switching a Mercury bulb ON again, wait for 15 minutes (about) until it cools down.

## 9-3. Operation

### **Danger : Electric Shock**

- Before connecting or disconnecting a load cable from the receptacles, always turn the circuit breakers (Main, 3-P, 1-P) to [OFF] position. And always stop engine, and remove the engine key. A person performing the maintenance should always keep the key.
- Ground the every grounding terminal to the earth as set out in the manual. If even one of all is unconnected by mistake or accident, it will be much more dangerous for human than the NO-RELAY case, because leaking current inevitably goes through the body. (Refer to 『5-6. Earth Leakage Relay』 )
- Even though all the current leakage relays in the loads have been grounded to the earth, the earth grounding terminal and the bonnet (canopy) should be grounded to the earth.
- Grounding should be made after the engine is stopped.
- Whenever the current leakage breaker activates, you should repair the leaking place first of all.

**⚠ Caution : Injuries**

- Be sure to connect to output terminals or insert a plug to a receptacle, after confirming that all the switches in the loads are positioned to [OFF].

**⚠ Caution : Damage to the property - Aftermath**

- Whenever connecting to use medical equipment or appliances, be sure to consult with the medical equipment company, doctor or hospital personnel.

<Caution>

- The AC Volt meter reads 3-P output voltage, apart from the circuit breakers (Main, 3-P, 1-P) positions to [ON] or [OFF], when the engine is driving.

After the engine starts (Refer to 『7-1. Starting』), operate the equipment as per the following procedures.

- ① Turn the power switch to [OFF] in the load.
- ② Turn the breakers ( Main, 3-P, 1-P) to [OFF].
- ③ Connect the load to the output receptacles.
- ④ Turn the breakers (Main, 3-P, 1-P) to [ON].  
(Ensure the ELCB lever to be positioned at [ON].)

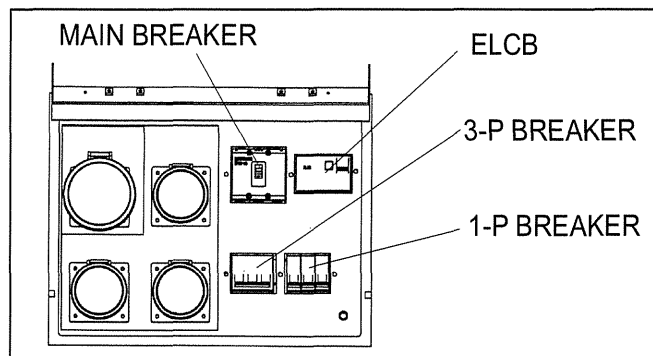

- The Circuit Breaker has activated due to overload

**⚠ Caution: Injuries**

- Be sure to turn the power switch OFF in the load when turning the circuit breaker to [ON] again, when the circuit breaker has activated.

When the electric supply exceeds the rated output (overload), the circuit breaker activates to trip off in order to shut down the circuit. When the load operation stops during operation, check the circuit breakers (Main, 3-P, 1-P).

In the case the ELCB activates and the ELCB lever positions at [OFF], refer to 『5-6. Earth Leakage Relay』.

When any breaker has tripped, restore the circuit breaker as per the following procedure.

- ① Turn OFF all the power switches in the loads.
- ② Turn (push) up the breaker to [ON].

<Caution>

- Take care for overload, referring to 『9-2. Output Limitation』.

## 10. Simultaneous Use of Welding and Generating

The circuit breakers (Main, 3-P, 1-P) react on the AC power supply circuit only. In the simultaneous use of welding and generating, there sometimes happens overload to the engine. Refer to the following table and limit the AC power use.

### ■ Limitation of AC Power Supply in the simultaneous use of welding and generating

Welding Output		AC Power Output			
Operators	Amperage	3-Phase (P.F. = 0.8)	1-Phase (P.F. = 1.0)	BOTH 3 & 1 -Phase	
1 Person MODE : [SINGLE] or [DUAL]	60A	15.0kVA	10.8kW	12.0kW	
	100A	15.0kVA	10.8kW	12.0kW	
	150A	14.5kVA	10.8kW	11.5kW	
	200A	12.5kVA	10.0kW	10.0kW	
	250A	10.0kVA	8.0kW	8.0kW	
	300A	7.5kVA	6.0kW	6.0kW	
	400A	1.5kVA	1.0kW	1.0kW	
	500A	0 kVA	0 kW	0 kW	
2 Persons MODE : [DUAL]	60A × 2	15.0kVA	10.8kW	12.0kW	
	100A × 2	13.5kVA	10.8kW	10.8kW	
	150A × 2	9.5kVA	7.5kW	7.5kW	
	200A × 2	5.5kVA	4.0kW	4.0kW	
	250A × 2	1.0kVA	0.5kW	0.5kW	
	280A × 2	0 kVA	0 kW	0 kW	

<Caution>

- Avoid the simultaneous use in the case high quality result in welding is required.

## 11. Checking and Maintenance

### ⚠ Danger : Electric Shock · Injuries

- Before performing any equipment check or maintenance, stop the engine, and remove engine key. A person performing the maintenance should always keep the key.

### ⚠ Caution: Fire · Burns

- Keep the equipment far away from fire.
- When checking engine, always stop the engine, and keep away from fire. Wait until the engine cools down, before performing any checks.
- Do not open the radiator cap while operating this equipment or immediately after stopping the equipment, to avoid sustaining burns from hot vapor.
- Do not open the side door during operation and immediately after stopping the equipment, because some parts/components (flexible tube, resistors, etc.) can reach very high temperature inside the equipment.

<Caution>

- The authorized technicians should perform all checking and maintenance work, except for the pre-startup checks.
- Request for the maintenance item with ● mark to the authorized distributor or our engineering section.
- Always use our genuine parts of replacement.
- When draining waste fluid from the equipment, catch it by tray.
- When disposing of oil, fuel, coolant (LLC), fuel filter, battery and /or other harmful disposal, please follow the international/federal regulations.
- Please do not dispose the harmful items or waste fluid to the ground to a river, pond, and ocean to keep our environment clean and neat.

To optimize the use of this generator/welder, we recommend the periodical equipment checks and maintenance based on the following matrix.

Use the hour meter as a guide for the operating time.

Checking Items		Startup Check	Checking Time					
			At 50hrs	Every 100 hrs	Every 200 hrs	Every 400 hrs	Every 1000 hrs	Every 2000 hrs
1	Check and Supply Fuel	○						
2	Check and Supply Engine Oil	○						
3	Engine Oil Change		1 <sup>st</sup> ○	2 <sup>nd</sup> or after ○				
4	Oil Filter Change		1 <sup>st</sup> ○		2 <sup>nd</sup> or after ○			
5	Check/Add Water/Coolant	○						
6	Water/Coolant Change							○ or one year
7	Clean Fuel Strainer		1 <sup>st</sup> ○	2 <sup>nd</sup> or after ○				
8	Change Fuel Filter					○		
9	Check Water Separator	○						
10	Drain Water/Clean Water Separator					○		
11	Drain Water/Clean Fuel Tank				○			
12	Check Leakage Fuel, Oil, Water	○						

Checking Items		Startup Check	Checking Time					Every 2000 hrs
			At 50hrs	Every 100 hrs	Every 200 hrs	Every 400 hrs	Every 1000 hrs	
13	Check/Add Battery Water	○			○ Clean	○ Change		
14	Clean Air Element		1 <sup>st</sup> ○	2 <sup>nd</sup> or after ○				
15	Change Air Element					○		
16	Adjust Tension V-Belt		1 <sup>st</sup> ●	2 <sup>nd</sup> or after ●				
17	Change V-Belt					● or 2 years		
18	Clean Radiator Fin					●		
19	Clean Radiator (inside)					●		
20	Change Fuel Hose, Oil Hose, Vibration-Absorbing Rubber							● or 2 years
21	Adjust Engine Valve Clearance						● Adjust	● Plane
22	Check/Adjust Injection Nozzle					●		
23	Check/Adjust Injection Pump							●

### (1) Oil Change

First Time	50 hour mark
2 <sup>nd</sup> or after	Every 100 hours

- ① Remove the oil plug.
- ② Loosen the oil drain plug and allow the oil to drain fully.
- ③ Reinstall the oil drain plug.
- ④ Checking the oil level by the oil level gauge, add oil into the oil filler to fill up to the max level (about 6.0L).
- ⑤ Reinstall the oil plug hand tight.

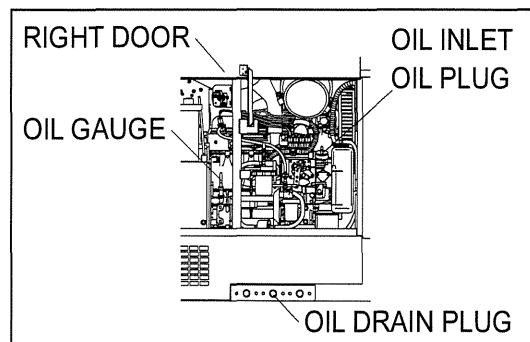

#### <Caution>

- Refer to 『6-1. Checking Engine Oil』 to select engine oil.
- Change the packing, whenever changing oil.
- Packing No. : 6C090-58961 (Kubota)

## (2) Oil Filter Change

First Time	50 hour mark
2 <sup>nd</sup> or after	Every 200 hours

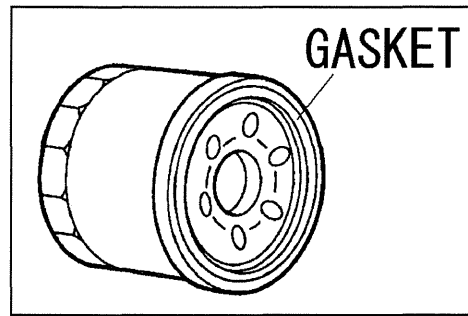
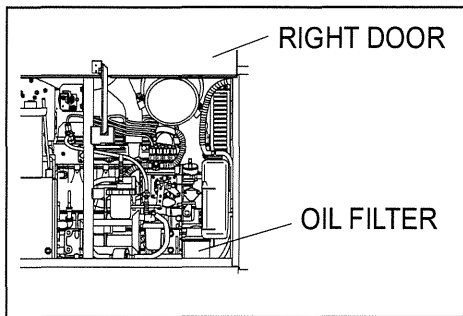

- ① Drain the engine oil completely, as described in 『11 (1) Oil Change』 .
- ② Loosen and remove the oil filter, using an oil filter wrench.
- ③ Smear a little engine oil on the rubber gasket of a new filter.
- ④ Screw the new filter into place and tighten it by hand until the gasket contact the seat. Then, give it additional 『1.1/4 Turn』 to seat the filter, using an oil filter wrench.
- ⑤ Supply oil and install the filler cap.

### <Caution>

- If an oil filter wrench is not available, contact our authorized distributor or our engineering section.
- Oil Filter Part No. : 16271-32093 (Kubota)

## (3) Clean/Change Air Filter Element

Clean	1 <sup>st</sup> 50 hours and Every 100 hours afterwards
Replace	Every 400 hours

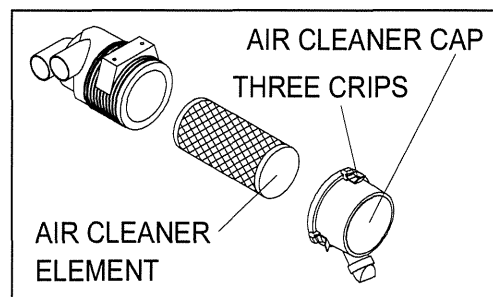
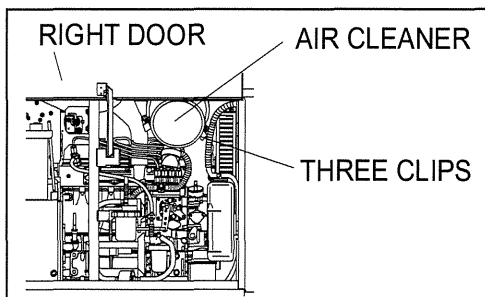

- ① Disconnect the Air Cleaner Cap by releasing the three clips
- ② Remove the air element.
- ③ Clean or replace the air element.
  - <The element is adhered with dried contaminants>  
Blow up compressed air from inside the element.
  - <The element is adhered with carbon or oil>  
Replace to a new one.
- ④ Reinstall them in reverse order.

### <Caution>

- Clean more frequently, if it is used in dusty environment.
- Element Part No. : R1401-42271 (Kubota)

#### (4) Clean/Change Fuel Strainer

Clean	1 <sup>st</sup> 50 hours and Every 100 hours afterwards
Replace	Every 400 hours

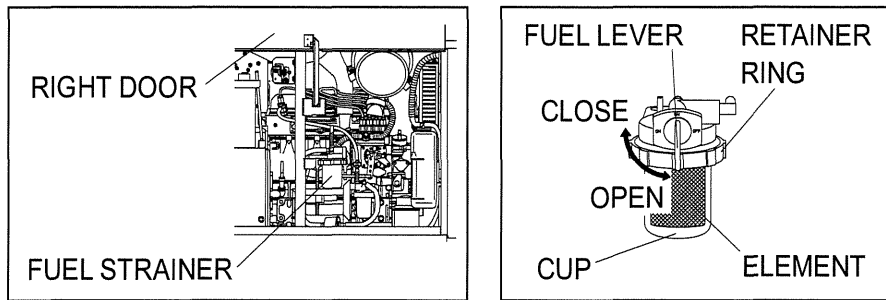

- ① Turn the fuel lever to [CLOSE].
- ② Unscrew the retainer ring counterclockwise, and remove the cup and the filter element.
- ③ Discard any dust or water inside the cup, and clean the filter element by blowing compressed air, or replace if necessary.
- ④ Reassemble it back.

#### <Caution>

- Be sure to check for any contaminants on the packing, whenever reinstalling the cup.
- Turn the fuel lever to [OPEN] after assembling, and check for any leak. Having confirmed no leak without fail, turn the fuel lever to [CLOSE].
- Element Part No. : 15521-43161 (Kubota)

#### (5) Drain Water from Water Separator

Drain	Every 400 hours
-------	-----------------

When the Float (red) is coming up to Drain Water Drain Line, drain the water.

- ① Turn the fuel lever to [CLOSE].
- ② Unscrew the retainer ring counterclockwise, and remove the cup and the gauze filter.
- ③ Dispose water or dirt inside the cup.  
When dirt is adhered to the gauze filter, clean the filter by compressed air.
- ④ Reassemble it back.

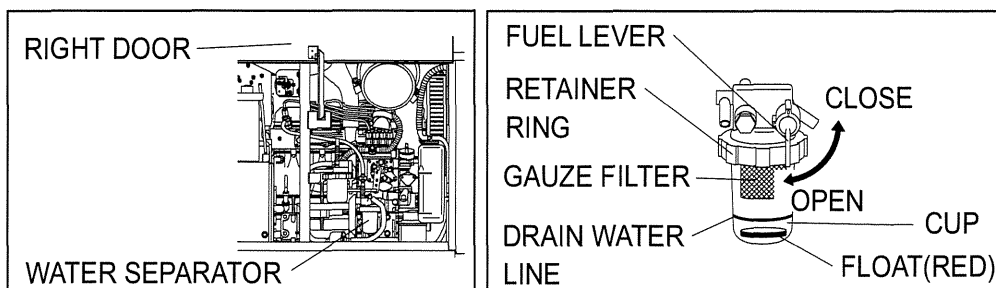

#### <Caution>

- Be sure to check for any contaminants on the packing, whenever reinstalling the cup.
- Turn the fuel to [OPEN] after assembling, and check for any leak. Having confirmed no leak without fail, turn the fuel lever to [CLOSE].



## (6) Drain Water from Fuel Tank

Drain Water	Every 200 hours
-------------	-----------------

- ① Unscrew the fuel drain plug.
- ② Reinstall the drain plug, after draining water completely

<Caution>

- Change the packing, whenever changing oil.
- Packing Part No. : 6C090-58961 (Kubota)

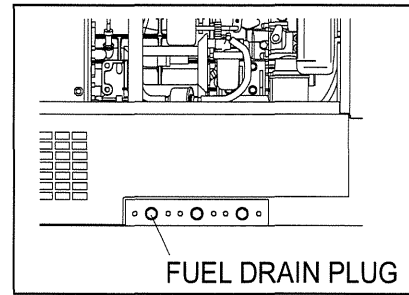

## (7) Changing Coolant/Water

Replace	Every 2 years or 2000 hours
---------	-----------------------------

(Total Coolant/Water Capacity: about 5.6 L, including sub tank cap. 0.8 L)

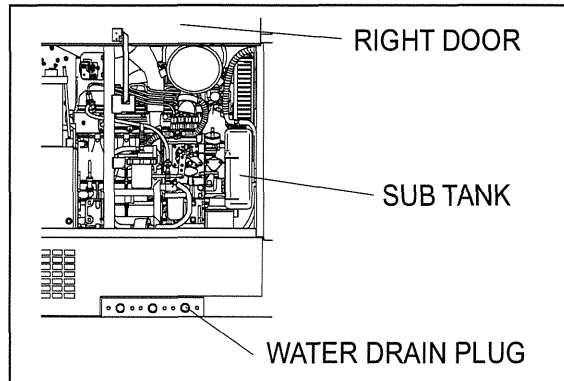
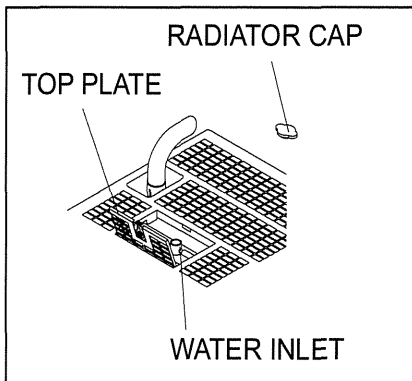

- ① Open the top plate.
- ② Remove the radiator cap.
- ③ Loosen the water drain plug.
- ④ After draining all the water, reinstall the water drain plug.

<Caution>

- Change the packing, whenever changing oil.
- Packing Part No. : 6C090-58961 (Kubota)

- ⑤ Replace all the water in the sub tank.
- ⑥ Fill the coolant/water to the MAX level (to the upper edge of the inlet).
- ⑦ Reinstall the radiator cap.
- ⑧ Close the top plate.

## 12. Long-Term Storage

### Danger : Electric Shock

- Before performing any equipment check or maintenance, stop the engine, and remove the engine key. A person performing the maintenance should always keep the key.

### Caution : Injuries

- Before performing any equipment check or maintenance, stop the engine, and remove the engine key. A person performing the maintenance should always keep the key.

### Caution : Fire · Burns

- When checking engine, always stop the engine, and keep far away from fire. Temperature around muffler and exhaust can get extremely high. Wait until the engine cools down, before performing any checks.

If the generator/welder will not be used for more than two months, perform the following maintenance and storage procedures.

- ① Remove the battery.
- ② Change the engine oil.
- ③ Drain fuel from the fuel tank, the Fuel Strainer and the Water Separator.
- ④ Clean all parts, cover the generator/welder, and keep it in the storage, away from dust and humidity.

<Caution>

- Recharge the removed battery once a month.

### 13. Troubleshooting

#### **Danger : Electric Shock**

- Do not operate the equipment, if the equipment or you are wet.  
Before performing any equipment check or maintenance, stop the engine.

#### **Caution : Injuries**

- When performing equipment check and maintenance, always stop the engine.

#### **Caution : Fire - Burns**

- When checking engine, always stop the engine, and keep away from fire.  
Temperature around engine, muffler and exhaust can get extremely high.  
Wait until the engine cools down, before performing any checks.

#### 13-1. Symptom and Countermeasures

Follow the guideline below, when performing any troubleshooting. If you cannot resolve the problems by this troubleshooting guide, contact the authorized distributor or our engineering section to request the repair.

Symptoms	Possible Cause	Corrective Actions
Starter motor does not start	<ol style="list-style-type: none"> <li>1. Battery Isolator Lever is [OFF] position</li> <li>2. Weak Battery</li> <li>3. Dead Battery</li> </ol>	<ol style="list-style-type: none"> <li>1. Turn Battery Isolator Lever to [ON] position</li> <li>2. Recharge Battery</li> <li>3. Replace Battery</li> </ol>
Engine does not start	<ol style="list-style-type: none"> <li>1. Fuel lever on fuel strainer or water separator to [CLOSE].</li> <li>2. Insufficient Fuel</li> <li>3. Emergency Stop Switch keeps pushed</li> <li>4. Fuse burnt</li> <li>5. Fuel is contaminated by the water or dust</li> <li>6. Fuel pump malfunction</li> </ol>	<ol style="list-style-type: none"> <li>1. Open the fuel lever for both fuel strainer and water separator</li> <li>2. Replenish fuel</li> <li>3. Release the Emergency Stop Switch</li> <li>4. Repair the fuse</li> <li>5. Drain water or clean fuel tank, fuel strainer, and fuel separator</li> <li>6. Repair the fuel pump</li> </ol>
Engine starts, but stalls immediately	<ol style="list-style-type: none"> <li>1. Insufficient oil</li> <li>2. High Water Temperature, Insufficient coolant/water</li> <li>3. Unable to charge</li> </ol>	<ol style="list-style-type: none"> <li>1. Replenish oil</li> <li>2. Replenish coolant/water</li> <li>3. Repair</li> </ol>
No Welding Output	<ol style="list-style-type: none"> <li>1. Weld Terminals Switch is selected incorrectly as [REMOTE CONTROL]</li> <li>2. Exceeding Duty Cycle (The warning lamp is blinking)</li> </ol>	<ol style="list-style-type: none"> <li>1. Turn to [WELD TERMINALS ON] for either terminal A or B directly</li> <li>2. Stop the operation until the equipment cools down (the lamp to OFF)</li> </ol>

Symptoms	Possible Cause	Corrective Actions
Welding Arc is weak	<ol style="list-style-type: none"> <li>1. SINGLE/DUAL Selector Switch position is incorrectly selected to [DUAL] mode</li> <li>2. Wrong Output Control Dial position</li> <li>3. Arc Control Dial is set to negative(−) side for CC mode</li> <li>4. Improper connection of cables</li> <li>5. Improper Cable Diameter</li> <li>6. Improper connection to the base material</li> <li>7. Simultaneous Use of Welding and Generating</li> <li>8. Engine output is down</li> </ol>	<ol style="list-style-type: none"> <li>1. Turn to [SINGLE] mode</li> <li>2. Turn the dial clockwise</li> <li>3. Turn the Arc Control Dial clockwise to positive(+) side</li> <li>4. Connect securely</li> <li>5. Replace the cables based on the 『Welding Cable Selection』</li> <li>6. Connect securely</li> <li>7. Stop using AC Power output</li> <li>8. Keep duty cycle</li> </ol>
Excessive Welding Arc	<ol style="list-style-type: none"> <li>1. SINGLE/DUAL Selector Switch is to [SINGLE] mode</li> <li>2. Wrong Output Control Dial position</li> <li>3. Arc Control Dial is set to positive(+) side for CC mode</li> <li>4. CV/CC Selector Switch is selected for [CC] Mode</li> </ol>	<ol style="list-style-type: none"> <li>1. Turn to [DUAL] mode</li> <li>2. Turn the dial counterclockwise</li> <li>3. Turn the dial counterclockwise to negative(−) side</li> <li>4. Turn to [CC] mode</li> </ol>
Unable to weld the Cellulose rods	<ol style="list-style-type: none"> <li>1. [OTHERS] mode is selected for rod selection</li> </ol>	<ol style="list-style-type: none"> <li>1. Select [CELLULOSE] mode</li> </ol>
Unable to operate the wire feeder properly	<ol style="list-style-type: none"> <li>1. Wire feeder coupler is not connected properly</li> <li>2. Circuit protector is activated</li> <li>3. Improper power input for the wire feeder</li> <li>4. [CC] mode is selected incorrectly</li> </ol>	<ol style="list-style-type: none"> <li>1. Confirm the coupler for proper connection</li> <li>2. Reset the circuit protector</li> <li>3. Select the correct power input 42V/115V for designated wire feeder</li> <li>4. Select the [CV] mode properly</li> </ol>
No AC Output	<ol style="list-style-type: none"> <li>1. The breaker (MAIN or 3-P or 1-P or ELCB) positions to [OFF]</li> </ol>	<ol style="list-style-type: none"> <li>1. Turn to [ON]</li> </ol>
AC Output is weak	<ol style="list-style-type: none"> <li>1. The rated current of the load exceeds the rated output</li> <li>2. Use of Welding and Generating</li> </ol>	<ol style="list-style-type: none"> <li>1. Adjust according to 『OUTPUT LIMITATION』</li> <li>2. Stop Welding</li> </ol>
Unable to activate the AUTO IDLE mode	<ol style="list-style-type: none"> <li>1. Welding cables short circuit</li> <li>2. The power consumption of the load is 0.5A or below</li> </ol>	<ol style="list-style-type: none"> <li>1. Repair the short circuit</li> <li>2. Set the Idol Control to [HIGH] mode</li> </ol>
Engine does not stop	<ol style="list-style-type: none"> <li>1. Stop Solenoid malfunction</li> </ol>	<ol style="list-style-type: none"> <li>1. Turn the fuel lever to [CLOSE] to stop and repair</li> </ol>
Excessive Black smoke exhaust from muffler	<ol style="list-style-type: none"> <li>1. Overloaded use</li> </ol>	<ol style="list-style-type: none"> <li>1. Operate the machine within the rated output</li> </ol>

### 13-2. Error Code Display

Inspect the following items accordingly when the Error Code E01 – E04 are displayed on the control panel.

Error No.	Possible Causes	Corrective Actions
E01 [OVER HEAT] Monitor Lamp is also blinking	Alternator and/or control parts Overheat	Turn the Idle Control Switch to [AUTO] and cool down the unit with no-load operation until [OVERHEAT] Monitor Lamp blinking will be stopped. Stop the engine after the [OVERHEAT] Monitor Lamp blinking will be stopped, then restart the engine. ※Operate the unit properly based on the operation manual to avoid overload, over-duty cycle, unclosed door, and / or intake/exhaust clogging etc.
E02	Control parts Malfunction	Shut off the engine immediately and resolve the malfunction components. ※Consult your dealer for necessary inspection
E03	Welding output Short Circuit	Shut off the engine immediately and confirm if there is short circuit on the welding output. Start the engine after resolving the troubled area for recovery.
E04	Incorrect Welding Mode Selector	Shut off the engine immediately and resolve the malfunction components. ※Consult your dealer for necessary inspection

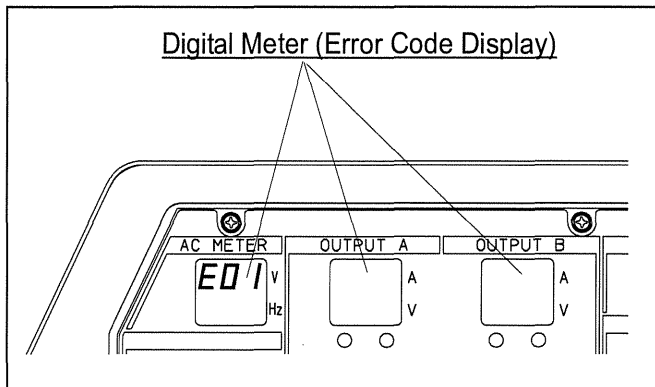

# 14. Engine Wiring Diagram

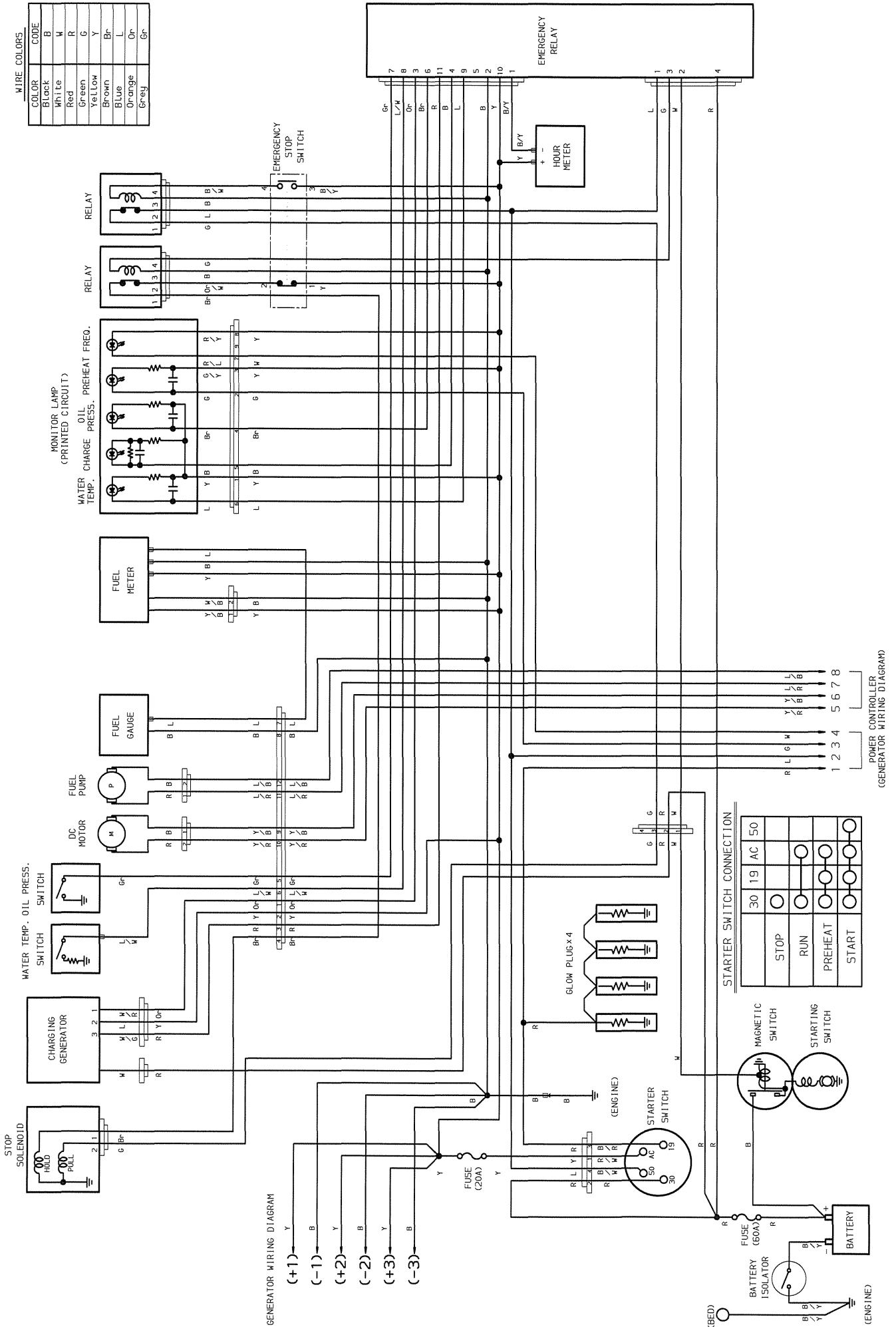



# 15. Generator Wiring Diagram

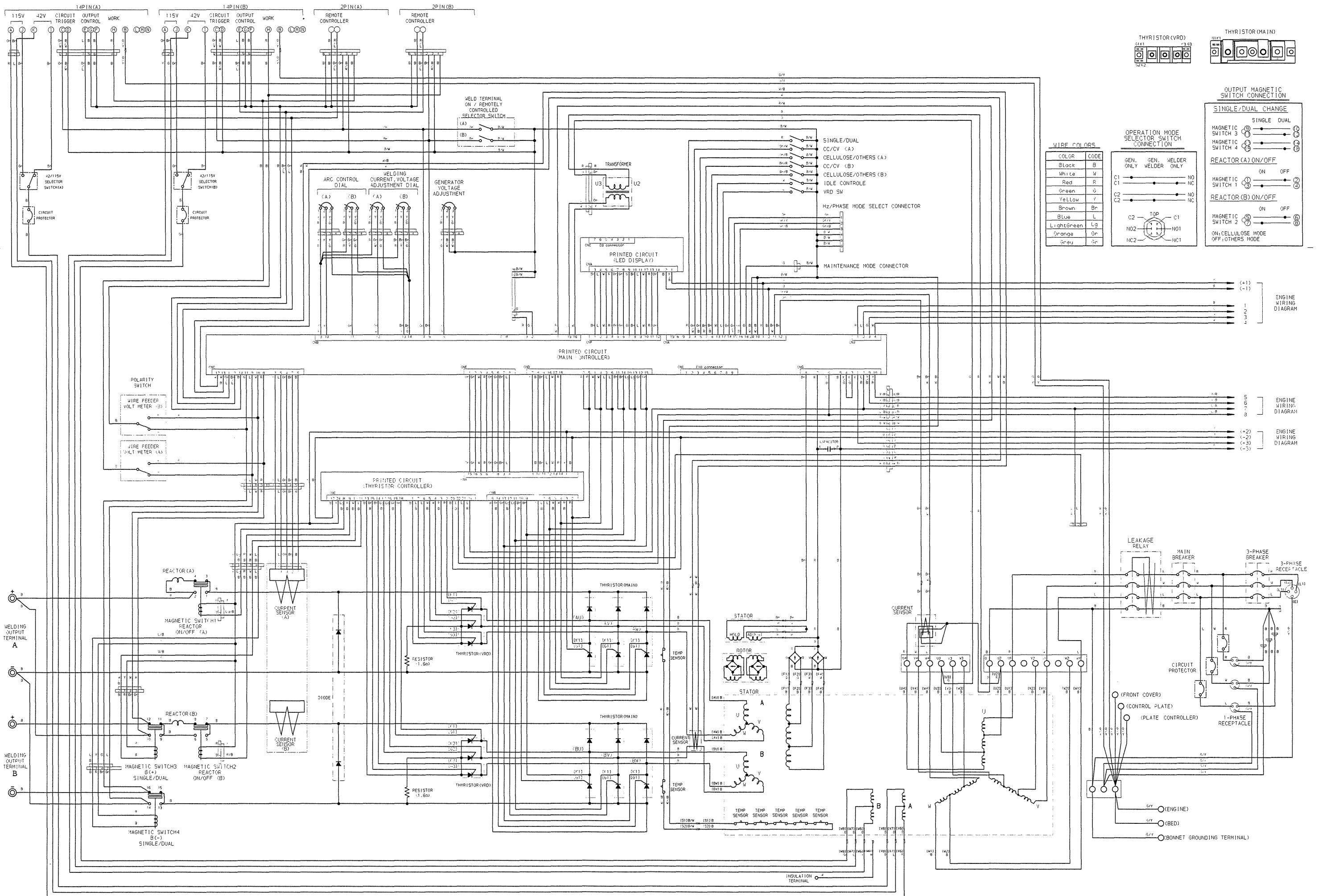







**YAMABIKO CORPORATION**

7-2 SUEHIROCHO 1-CHOME, OHME, TOKYO 198-8760, JAPAN

PHONE: 81-428-32-6118. FAX: 81-428-32-6145.

**shindaiwa**