

shindaiwa[®]

OWNER'S MANUAL



DGW400DM-C

1. Introduction

Thank you for purchasing this Shindaiwa Sound Attenuated Diesel Engine Powered Welder/Generator.

- This manual was created to help ensure the safe operation of this equipment. To avoid unnecessary accidents and/or repairs, it is strongly recommended that the user closely follow all the instructions contained in this manual.
- Do not operate this equipment until you have thoroughly read and understand the contents of this manual.
- For easy reference, this manual should always be stored on or near the equipment.

The following convention will be used throughout this manual to indicate various degrees of warnings.

 Danger	<i>Can cause serious injuries or death.</i>
 Caution	<i>Can cause minor injuries or damage to the equipment or other properties.</i>
<Caution>	<i>Other types of caution</i>

- Even some of the items noted in  **Caution** may lead to serious injuries. Be sure to fully read and understand all instructions prior to operating this equipment and follow all safety guidelines during equipment operation.

2. Safety Guidelines

Danger: Suffocation from exhaust fumes

- Exhaust fumes from the engine used on this equipment contain many elements that have been proven to be harmful to humans. Do not operate this equipment without adequate ventilation.

Danger: Electric Shock

- Do not come in contact with the output terminals during operation.
- Do not insert metal objects (such as pins or wires) into plug-in receptacles.
- Do not touch any wiring or electrical parts inside the equipment during operation.
- Before connecting or disconnecting a load cable from the output terminals, ensure that the output circuit breaker is in the OFF position.
- Before connecting or disconnecting welding cables from the output terminals, stop the engine and remove the engine key. The person connecting or disconnecting the cables should always retain possession of the key.
- Before performing any equipment check or maintenance, stop the engine and remove the engine key. The person performing the maintenance should always retain possession of the key.

Danger: Burns

- To avoid sustaining burns from hot vapor, do not open the radiator cap either while operating or immediately after stopping this equipment.

Danger: Injuries

- To avoid injuries due to accidental contact with the cooling fan, fan belt, or other moving parts, close and lock all doors during the operation of this equipment.

Caution: Suffocation from exhaust fumes

- Direct exhaust fumes away from other personnel and/or buildings.

Caution: Suffocation from welding fumes

- Welding fumes may contain poisonous gas and/or dust. Ensure that there is adequate ventilation of the welding area and if necessary, that the proper respiratory equipment is worn.

Caution: Injuries to eyes and skin

- Welding helmets or hand shields containing appropriate filter lenses and cover plates must be worn during welding operations.
- Always wear the proper protective clothing such as long sleeve shirts, pants without cuffs, covered pockets, sturdy shoes or boots, and durable gloves while welding.
- Battery fluid contains dilute sulfuric acid. Avoid contact with the eyes, skin or clothing. If contact with the acid does occur, especially with the eyes, flush with large volumes of clean water, and contact your physician immediately.

Caution: Electric shock

- Keep water and moisture from entering the interior of the enclosure.

⚠ Caution: Explosion

- Do not use this equipment or charge the battery if the battery fluid level is lower than the LOWER level mark on the battery case.
- The battery may emit highly explosive gases. Never expose it to flames or spark producing devices.

⚠ Caution: Fire

- This equipment uses diesel (a flammable liquid) as a fuel. When refueling, always stop the engine and maintain an adequate distance from flames and spark producing devices. Allow the engine to cool down before refueling.
- Immediately wipe up any diesel fuel or engine oil that may be spilled. Do not use this equipment if there are any fuel or lube oil leaks. Repair the equipment before further use.
- Temperatures around the muffler and exhaust piping can get extremely high. Keep any flammable items (such as fuel, gas, paint, cloth, paper etc.) away from these areas.
- Keep flammable items away from the welding area to prevent ignition of these items by welding spatter.
- This equipment must be operated only on flat stable surfaces and at least 3 feet away from any obstructions (such as walls) that would hinder airflow.
- Do not connect the AC output to any indoor wiring without an approved disconnecting device between the generator output and the building's electrical service and then only if done by a qualified electrician.
- Allow the equipment to cool down before covering it for storage.

⚠ Caution: Burns

- Due to the extremely high temperatures in these areas, do not come in contact with the engine or muffler during operation or immediately after stopping the equipment.
- Do not check or change the engine oil while the engine is running. Stop the engine and allow it to cool down prior to checking or changing the engine oil. Opening either the line to the oil gauge or the oil filler cap during operation may cause injury due to hot oil.
- Always wear the proper protective clothing such as long sleeve shirts, pants without cuffs, covered pockets, sturdy shoes or boots, and durable gloves while welding.

⚠ Caution: Injuries

- Lift this equipment only with the installed lifting hook.
- Operate this equipment only on a flat and stable surface. For wheeled models, lock the wheels during operation.
- Never start the engine with loads connected to the generator output. Prior to starting, disconnect the loads and turn the main output circuit breaker to OFF.
- Do not move this equipment during operation.
- Stop the engine before performing any equipment checks and/or maintenance.
- Do not operate this equipment if it is being modified or if any parts have been removed.

3. Labels

Caution, Danger, Warning and Operation Information Labels: Make sure all information labels are undamaged and readable. Immediately replace damaged or missing information labels. New labels are available from your local authorized Shindaiwa distributor or dealer.

When ordering labels, use the following part numbers:

- 1 Suffocation from exhaust fumes (No. 19402-00194)
- 2 Suffocation from welding fumes (No. 19402-00195)
- 3 Electric Shock (No. 19402-00193)
- 4 Burns (No. 19402-00201)
- 5 Injuries (No. 19402-00199)
- 6 Burns (No. 19402-00200)
- 7 Fire (No. 19402-00166)
- 8 Burns (No. 19402-00256)
- 9 Caution Earth Leakage (No. 19402-00187)

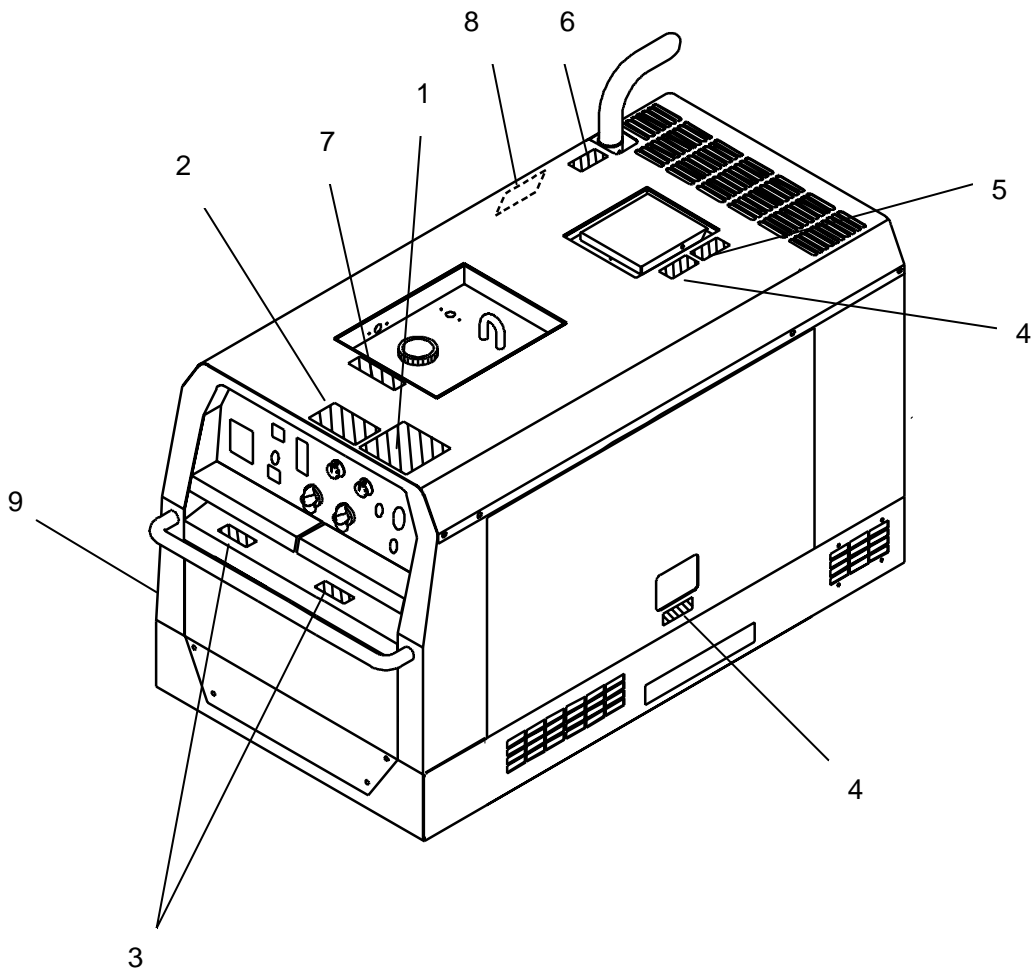

4. Specifications

Model		DGW400DM - C			
Generating Method		Rotating Field			
Welding Generator	Rated Current (A)		390 @ 60% Duty Cycle, 302 @ 100% Duty Cycle		
	Rated Voltage (V)		35.6		
	Rated Speed (rpm)		3600		
	No Load Voltage (A)		MAX 85		
	Output Change (CC power)	Single	Current Adj. Range (A)	110 - 400	
			Welding Rod Diameter	5/64 – 5/16	
	Dual	Current Adj. Range (A)	55 - 210		
		Welding Rod Diameter	5/64 – 5/32		
Eco	Current Adj. Range (A)	40 – 220			
	Welding Rod Diameter	5/64 – 3/16			
AC Generator	Rated Frequency (Hz)		60		
	Rated Speed (rpm)		3600		
	Phase		1-Phase	1-Phase	3-Phase
	Rated Voltage (V)		120	240	480
	Power Factor		1.0	1.0	0.8
	Rated Output (kVA)		2.2	4.3	15
	Rating		Continuous		
Engine	Model		Kubota D1005		
	Type		Vertical, Water-Cooled 4-Cycle Diesel Engine		
	Displacement (L)		1.001		
	Rated Output (kW/rpm)		20.4/3600		
	Fuel		ASTM No.2 Diesel Fuel or Equivalent		
	Lube Oil		API Class CC or Higher		
	Lube Oil Volume (Quarts/L)		5.4/5.1		
	Cooling Water Volume (Quarts/L)		4.5/4.3		
Starting Method		12V DC Starter Motor			
Battery		55B24L			
Fuel Tank Capacity – (Gallons/L)		9.8 /37			
Dimension	Length – (Inches/mm)		59.8/1519		
	Width - (Inches/mm)		27.6/700		
	Height – (Inches/mm)		29.9/760		
Dry Weight – (Pounds/kg)		972/441			

5. Use

- Arc Welding (CC or CV), MIG, TIG, Gouging
- CV Power Output (Side A only)
- Auxiliary AC power source up to the rating of the AC generator.

⚠ Caution: Potential damage to this equipment or other equipment

- This equipment is designed for the above purposes only. Do not use it for any other purposes.

6. Parts

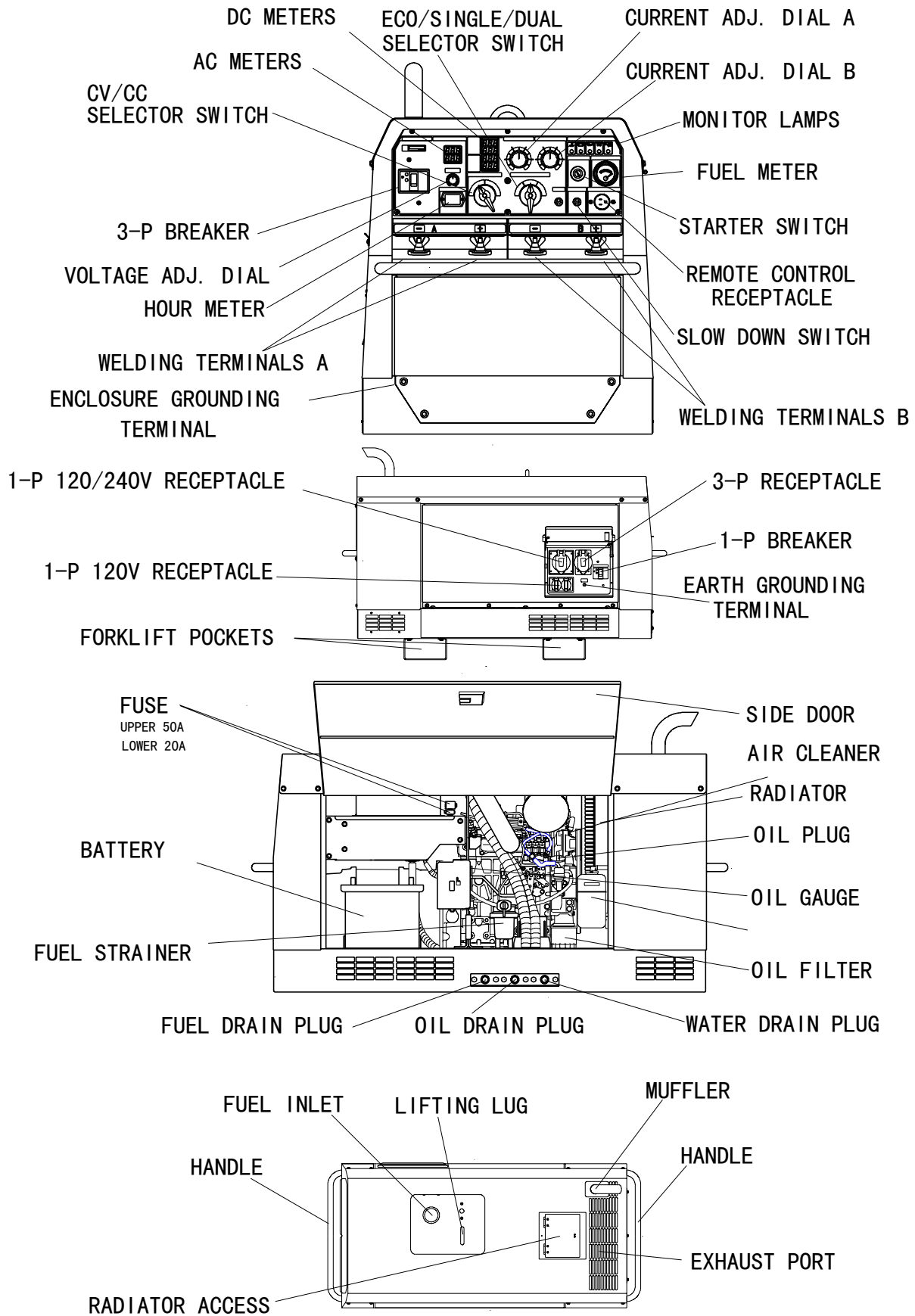

7. Equipment

7-1 Eco Welding

This equipment incorporates the Eco welding feature that allows welding operations at a reduced speed (2100 rpm) which results in lower noise levels, reduced fuel consumption and lower emission levels than with conventional welders.

With the selector switch in the Eco position, welding can be done with up to 3/16" (5.0 mm) welding rod even though the engine is turning at a reduced speed.

<Caution>

- Do not turn the output selector switch while welding.
- The Eco feature is available for welding only. In the Eco mode the generator output is not available.

7-2. CV/CC

Side A of this welder can be a Constant Voltage Power Source. By connecting a wire feeder to side A, and then turning the CC/CV Selector Switch to CV, you have the ability to perform semi-automatic welding such as MIG, MAG, SS, etc.

When the CC/CV selector switch is positioned to CV, Side A terminals become a Constant Voltage Power Source. In this position voltage is adjusted with the voltage adjust dial A.

When the CC/CV selector switch is positioned to CC, Side A terminals become a Constant Current Power Source. In this position current is adjusted with the current adjust dial A.

<Caution>

- Do not turn the output selector switch while welding.
- Side B Output Terminals can be used only as a Constant Current Power Source.

7-3. Remote Control (Optional)

Remote control operation using the Side A Terminals is available by plugging a remote control into the receptacle on the lower right side of the control panel. This will allow you to adjust either welding voltage or welding current from the Side A Terminals up to 295 feet away from the welder when using an optional extension cord.

Remote Control Connection

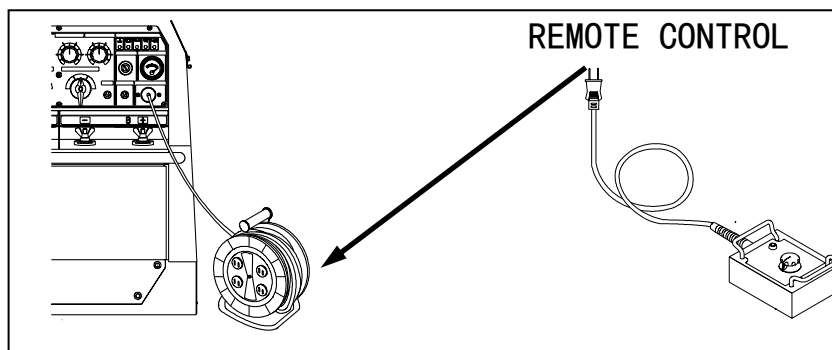

<Caution>

- Do not plug the remote control box into any energized AC receptacle.
- Do not connect other loads to the circuit that is powering the remote control.

7-4. Meters

This equipment features reliable digital meters for welding voltage and current and alternator three phase output voltage and frequency

DC Volt Meter and Ampere Meter for welding Side A and Side B.

- When the output selector switch is positioned at [Eco] or [Single], the Side B meters are inoperative.

3-Phase Volt Meter

- This meter displays the 3-Phase output voltage of the AC generator.

Frequency Meter

- This meter displays the AC generator output frequency in Hertz.

7-5. Monitor Lamps

This equipment has monitoring lamp indication for WATER TEMPERATURE, BATTERY CHARGING, OIL PRESSURE, PREHEAT, AND OVERHEAT.

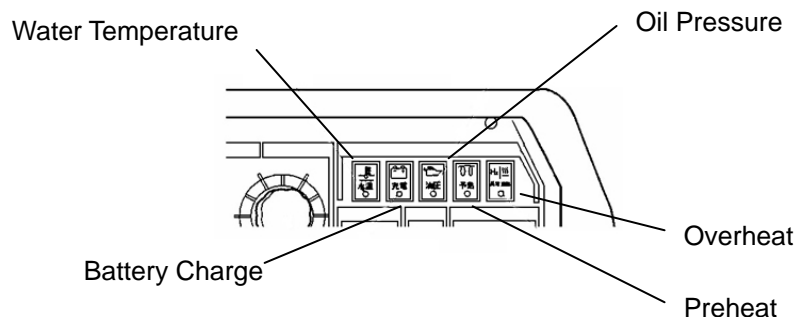

When the starter switch is placed in the RUN position, the monitoring lamps indicating BATTERY CHARGING, OIL PRESSURE and OVERHEAT will turn ON. Once the engine starts, if there are no abnormalities in the parameters these circuits monitor, the lamps will turn OFF. If an abnormality is detected on any of the circuits monitored, other than OVERHEAT, the corresponding monitor lamp will flash, and the engine will automatically shut down. An OVERHEAT abnormality will cause the lamp to flash and the output of the welder to be decreased.

If there is an automatic shutdown, turn the starter switch to the STOP position. Investigate the cause of and correct the reason for the shutdown prior to trying to restart the engine.

Coolant/Water Temperature Monitor Lamp

Danger: Injuries

To avoid accidental contact with the cooling fan or fan belts, do not operate this equipment unless all doors are closed.

Danger: Burns

To avoid sustaining burns from hot vapor, do not open the radiator cap while operating or immediately after stopping this equipment

Caution: Burns

Due to extremely high temperatures, do not come in contact with the engine or muffler while operating or immediately after stopping this equipment.

If the water temperature rises to an unsafe level, the coolant/water temperature monitor lamp will flash, and the engine will automatically shut down. If this occurs, check the coolant/water reservoir tank, and refill it if needed. (Refer to Section 6-2 Checking Coolant/Water)

If the water level is normal after shutting down because of a coolant/water temperature monitoring lamp situation, there is a possibility that the machine is over loaded causing the coolant temperature to rise to an unacceptable level. Never operate this equipment at greater than the rated duty cycle and/or output power.

Battery Charge Monitor Lamp

If the battery becomes unable to be charged during operation, the battery charge monitor lamp will flash and the engine will automatically shut down. If this occurs, check the battery. (Refer to Section 6-5 Checking Battery)

<Caution>

- The battery charge monitor cannot detect the degradation of the battery or the battery fluid level. Check the battery fluid level periodically. (Refer to Section 6-5 Checking Battery)

Oil Pressure Monitor Lamp

Danger: Injuries

- To avoid accidental contact with the cooling fan or fan belts, do not operate this equipment unless all doors are closed.

Caution: Burns

- Due to extremely high temperatures, do not come in contact with the engine or muffler while operating or immediately after stopping this equipment.
- Prior to checking engine oil, stop the engine, and wait until the engine cools down. If you open either the oil gauge supply line or the oil filler cap during operation, hot oil may cause injury.

If the engine oil pressure drops to an unsafe level during operation, the oil pressure monitor lamp will flash, and the engine will automatically shut down. If this occurs, check the engine oil level, and refill to the maximum level if needed.

<Caution>

- The engine oil pressure monitor cannot detect the degradation of the engine oil itself. Check the engine oil periodically, and change it according to the manufacturer's recommendation. (Refer to Section 11 Maintenance.)

Overheat Monitor Lamp

- If this equipment is used at a capacity that exceeds its rating, it will automatically reduce the output to a satisfactory level and the OVERHEAT monitor lamp will flash.
- The OVERHEAT monitor lamp will also flash if the machine is being used in excess of its rated duty cycle.
- When the OVERHEAT monitor activates, the AC generator is not usable.

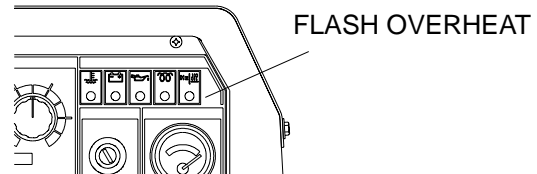

If the engine automatically shuts down and none of the monitor lamps are lit to indicate why it has shut down, check the 20 amp and 50 amp fuses located above the battery inside at the top of the enclosure. If either of these fuses is burned out, there is an electrical problem of some kind. Investigate the cause and correct it prior to trying to restart this equipment.

7-6. Earth Leakage Relay

⚠ Danger: Electric Shock

- Both grounding terminals of this equipment should be earth grounded prior to the operation of the equipment.
- Even though all the terminals of the loads may be grounded, the earth grounding terminal and the enclosure grounding terminal should be earth grounded.
- Grounding connections should be made only when the engine is stopped.
- If the earth leakage relay activates, determine the cause for the relay activation and correct it before restarting this equipment.

This equipment is provided with an earth leakage relay in the AC Circuit Breaker to detect current leakage to ground on the loads it is supplying. This circuit breaker will trip upon detecting excess current to ground to protect the operator(s) from possible electric shock.

The earth leakage relay is rated:

- Sensitive Current: 30mA (or less)
(Grounding resistance: 500 ohms or less)
- Sensitive time: Within 0.1 second

(1) Grounding

A qualified electrician should ensure grounding connections of 500 ohms or less at the following 3 points.

- The earth grounding terminal in the output receptacle enclosure.
- The Outer Enclosure of the equipment (enclosure grounding terminal).
- The Outer Enclosure of the load(s).

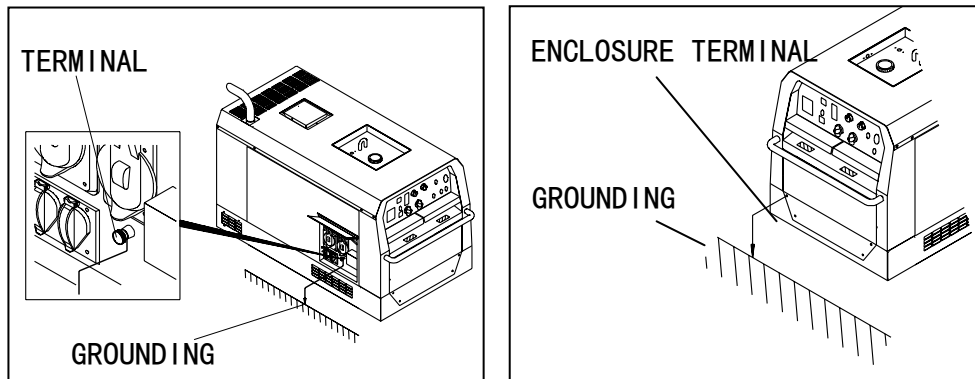

(2) Operation Check

Before operating this equipment, check the operation of the earth leakage relay as follows:

1. Start the engine.
2. Shut the Earth Leakage Circuit Breaker by turning it to the ON position.
3. Push the test button. The device is operating normally if the earth leakage indication lamp turns ON and the circuit breaker moves to the tripped position (between ON and OFF).
4. Push the reset button. The earth leakage indication lamp should turn OFF.
5. Reset the circuit breaker by pushing it down to the OFF position.
6. If the above sequence cannot be completed successfully, determine the cause of the problem and correct it before starting the engine.

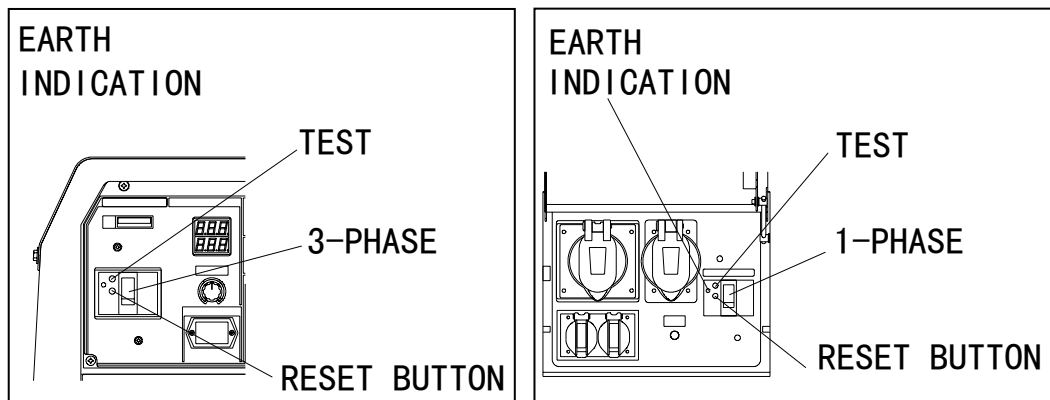

The Earth Leakage Relay has activated



Caution: Electric Shock / Injuries

- If the Earth Leakage Circuit Breaker trips, disconnect all loads connected to the AC Generator prior to resetting it.

When the earth leakage relay activates, the earth leakage indication lamp will turn ON and the circuit breaker lever will move to the tripped position (between ON and OFF).

If this happens, stop the engine, determine the cause, and correct it.

Once the cause of the problem has been corrected, the circuit breaker may be reset as follows:

1. Push the reset button.
2. Reset the circuit breaker by moving it first to the OFF Position and then back to the ON position.

<Caution>

- If the breaker trips but the lamp does not turn ON, there is either too much load on the AC generator or the output selector switch is in the Eco mode while trying to supply AC loads. If this occurs, determine the cause and correct it prior to trying to reset the breaker.

7-7. Slow-Down Feature

The slow-down feature automatically reduces engine speed when there is a period of approximately 8 seconds or more that there is no load on the engine and then automatically increases it once again as soon as there is a welding or AC generator demand. This feature results in less noise, lower emissions, reduced fuel consumption, and extended engine life.

The slow down feature can be turned on and off by using the Slow Down Switch toggle switch on the control panel.



Caution: Damage to the equipment or other properties

- If supplying loads with magnetic starters, do not use the Slow Down feature.

<Caution>

- Erratic operation of the Slow Down feature may occur when there is a load of less than 0.5A. If this occurs, the Slow Down feature should be turned OFF.
- If welding operations or electrical output become erratic, turn the Slow Down feature OFF.
- When the output selector switch is positioned to Eco with the Slow Down feature in ON, the engine will not return to high speed upon application of load.

7-8 AC Voltage Adjusting Dial

This dial is used to adjust AC output voltage when necessary.

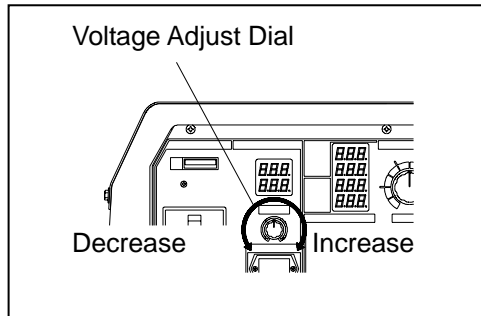

<Caution>

- Do not raise voltage beyond the rated capacity. Operating loads at higher than rated voltage can cause damage to the loads.
- Lowering voltage causes the loads to draw increased amperage which could result in damage to the loads.

8. Initialization and Pre-check

⚠ Caution: Fire, Burns, Injuries

- Prior to performing any checks or adjustments to the engine, stop the engine and allow it to cool down.

8-1 Checking Engine Oil

When checking the engine oil, keep the equipment level, and insert the oil dipstick all the way in. Prior to starting the equipment, make sure to fill the engine oil to the UPPER line through the oil inlet.

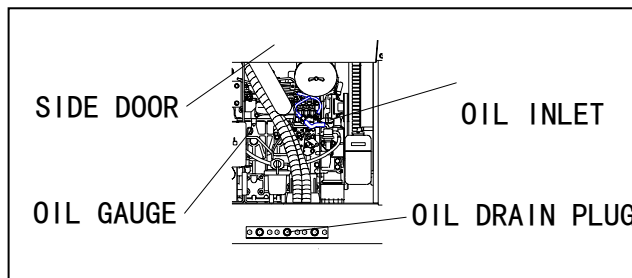

<Caution>

- If the equipment is not level, you cannot obtain an accurate oil level reading.
- Do not overfill (above UPPER line) the engine oil. Excessive engine oil may damage the engine.

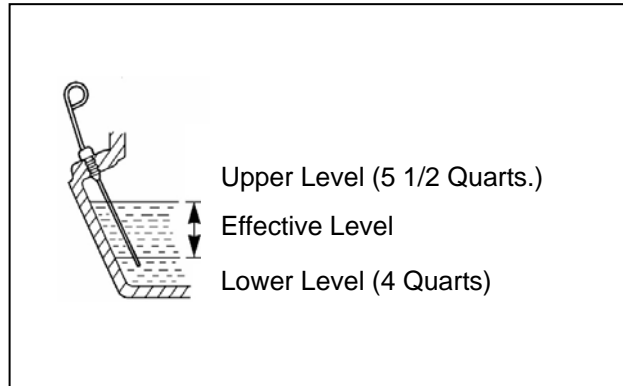

- Selecting the proper engine oil

<Caution>

- Use API class CC or higher engine oil.

Viscosity and Temperature

Temperature	Over +68°F	+50 to +67°F	-4 to +49°F
Viscosity	SAE30	SAE20	SAE10W/30

8-2 Checking Coolant / Water

⚠ Danger: Injuries

- To avoid accidental contact with the cooling fan or fan belts, do not operate this equipment unless all doors are closed.

⚠ Danger: Burns

- To avoid sustaining burns from hot vapor, do not open the radiator cap while operating or immediately after stopping this equipment

⚠ Caution: Burns

- Due to extremely high temperatures, do not come in contact with the engine or muffler while operating or immediately after stopping this equipment.

Check to see if the coolant/water level is between the FULL and LOW levels in the sub tank. If the coolant/water is below the LOW level, fill the tank and the radiator accordingly.

- (1) Filling the Sub Tank
 - 1 Remove the sub tank cap.
 - 2 Add coolant to the FULL level.
 - 3 Re-install the cap.

- (2) Filling the Radiator
 - 1 Remove the top plate.
 - 2 Remove the radiator cap.
 - 3 Add coolant to the top.
 - 4 Re-install the radiator cap.
 - 5 Re-install the top plate.

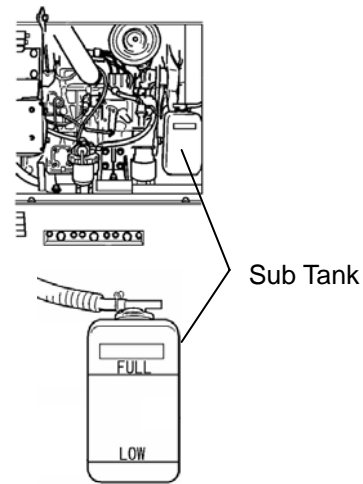

<Caution>

- Use soft water, such as tap water.
- If the ambient temperature is near freezing, use Long Life Coolant (LLC) at a mixture ratio of 30%-45%, depending on the ambient temperature.
- This equipment has a 30% mixture ratio of LLC when shipped from the factory.
- Replace LLC at yearly intervals or 2000 hours of operation whichever comes first.

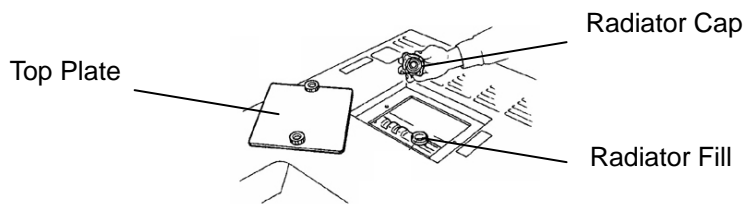

Suggested LLC Mixture Ratio

Lowest Ambient Temperature	+5°F	-4°F	-22°F
Mixture Ratio	30%	35%	45%

8-3 Checking Fuel

⚠ Caution: Fire

- Do not operate this equipment with any fuel leak. Wipe up any spilled fuel immediately.

Fuel tank level is indicated on an illuminated fuel gauge on the control panel. Check the fuel level prior to starting and refill if necessary.

<Caution>

- Use Diesel fuel, ASTM D975 No.2-D.

- To help prevent solid contaminants from entering the fuel system, the fuel fill strainer should always be used.
- To help prevent fuel spills, fill the fuel tank slightly less than full when refueling.

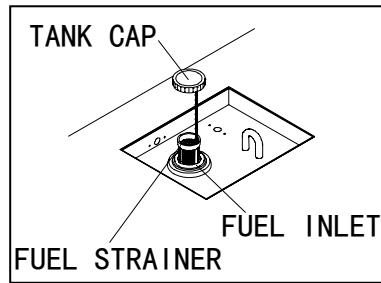

8-4 Checking Fuel, Engine Oil and Water Leakage

⚠ Caution: Fire

- Do not use this equipment if there is any fluid leakage. Repair the cause of the leak prior to starting the equipment.

Checking for fuel, oil and coolant/water leakage can be done by opening the side doors and visually inspecting all fluid connections.

8-5 Checking Battery

⚠ Caution: Injuries to eyes and skin

- Battery fluid contains diluted sulfuric acid. Avoid contact with eyes, skin or clothing.
- If contact with the acid does occur, especially with the eyes, immediately flush with large volumes of water and immediately contact a physician.

⚠ Caution: Fire

- The battery may emit highly explosive gases. Never expose it or the surrounding environment to flames or spark producing devices.

1. The factory installed battery has clear sides with the upper and lower fluid levels clearly marked. Do not operate this equipment unless the fluid level is between the upper and lower fluid level marks. If the fluid level is low, add distilled water to fill it to the upper level mark.

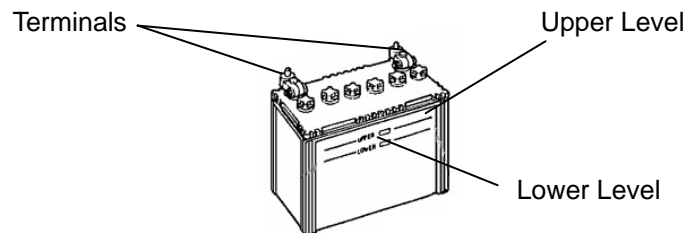

2. Make sure that the battery cables are firmly secured to the posts. Tighten the clamps if necessary.

3. The battery acid specific gravity should never be allowed to fall below 1.23. This may be checked by using a hydrometer. Re-charge the battery if specific gravity is below 1.23.

Replacing the battery

1. If battery replacement becomes necessary, remove the clamp and cable from the negative (-) post of the battery. Always remove the negative side first.
2. Remove the hold-down clamp from the battery.
3. Remove the clamp and cable from positive (+) post of the battery.
4. Remove the battery from the battery rack.
5. Reinstall a new battery in the reverse order. Always connect the positive (+) post of the new battery first.
6. The factory installed battery is a 55B24L.

9. Operation

Danger: Suffocation from exhaust fumes

- Exhaust fumes from the diesel engine on this welder contain many elements that have been proven to be harmful to humans. Do not operate this equipment without adequate ventilation.
- Do not direct exhaust fumes toward pedestrians or buildings.

Caution: Fire

- Temperatures around the muffler and exhaust piping can get extremely high. Keep any flammable items (such as fuel, gas, paint, etc.) away from these areas.
- This equipment must be operated on flat surfaces and, at least 3 feet away from any obstructions, such as walls, that could hinder air flow.

Caution: Injuries

- This equipment must be operated only on flat surfaces. Wheeled models must have the wheels locked in place prior to starting the equipment.
- Before starting the engine, be sure to disconnect all loads and open (OFF position) both the single phase and three phase breakers.

9-1 Starting

1. Turn the single phase and three phase breakers (1-P and 3-P) to the OFF position.
2. Open the fuel shutoff valve.
3. Turn the Slow-Down switch to ON.
4. In cold weather there may be a need to pre-heat the engine prior to starting. If this is the case, turn the start switch to the pre-heat position and hold it there until the pre-heat light goes out.
5. Turn the start switch to START.
 - Do not engage the starter motor for more than 15 seconds.
 - Wait 30 seconds or more between cranking cycles.
6. Release the start switch as soon as the engine has started. Once the engine has started, never turn the start switch to START.
7. Let the engine idle for approximately 5 minutes before welding or applying an AC load.

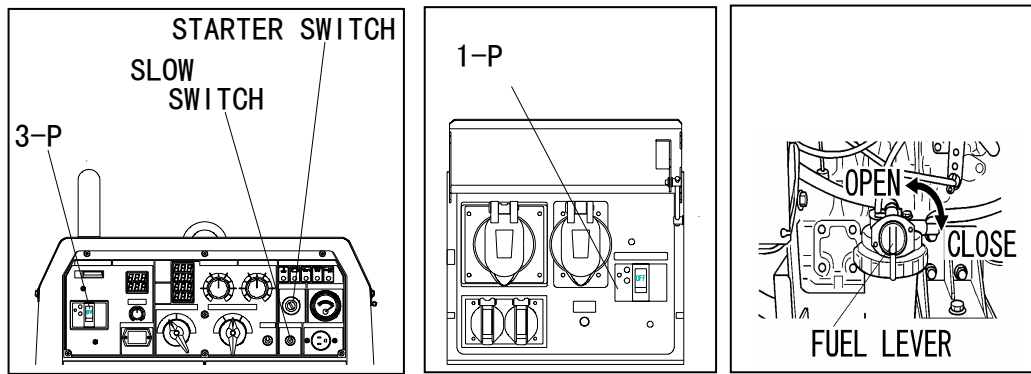

Restarting the engine after running out of fuel.

This equipment is equipped with an automatic air bleed feature that allows easily restarting the engine after running out of fuel. If this machine runs out of fuel, use the following procedure for re-starting.

1. Turn the start switch to the STOP position.
2. Refill the fuel tank.
3. Turn the Slow-Down switch to ON.
4. Turn the start switch to the START position and engage the starter motor for approximately 10 seconds until the engine starts.
5. Release the starter switch once the engine has started.
6. The engine will run erratically until all the air has been bled out. Wait for approximately 1 minute before adding load to allow the engine speed to become stable.

<Caution>

- Do not turn the Slow-Down switch to OFF or connect loads until the air is completely extracted. The air is completely extracted when engine speed becomes stable.

9-2 Stopping

1. Open (place in the OFF position) the single phase and three phase breakers (1-P and 3-P).
2. Turn the Slow-Down switch to ON.
3. Let the engine idle (cool down) for about 5 minutes.
4. Turn the start switch to the STOP position.
5. After the engine has stopped, shut the fuel shut-off valve.

10. Welding Operation

10-1 Selection – Welding Cable

Always use welding cable of sufficient size for the desired welding amperage at the distance from the welder that the welding will be occurring.

<Caution>

- Welding cables should be used unstrained. The ampacity of the welding cables is decreased if the welding cables are coiled.

10-2 Polarity

There are two welding output terminals, + and -.

Connect leads to the output terminals to correspond to the type of welding to be performed in accordance with the following table:

(1) Welding Rod

	Application	Connection
Normal Polarity	General Welding	+ To Ground (Material) - To Holder (Rod)
Reverse Polarity	Thin Plate, Build-Up Welding, Stainless Steel	+ To Holder (Rod) - To Ground (Material)

(2) Semi-automatic wire feeder

	Application	Connection
Normal Polarity	Self-Shield (Small Diameter)	+ To Ground (Material) - To Holder (Rod)
Reverse Polarity	MIG Welding MAG Welding Self-Shield (Big Diameter)	+ To Torch (Wire) - To Ground (Material)

10-3 Connection – Welding Cable

Danger: Electric Shock

- Before connecting or disconnecting welding cable from the welding output terminals, stop the engine, and remove the engine key. The person connecting or disconnecting the cable should maintain possession of the key.

1. Stop the engine.
2. Connect the welding cable securely to the welding output terminals that are to be used.
3. After connecting the cables, close the output terminal covers before commencing to weld.

Welding Rod

Eco (Single)	Single	Dual
Welding Rod 5/64 –3/16	Welding Rod 7/64 –5/16	Welding Rod 5/64 –5/32
Welding Output Terminal A	Welding Output Terminal A	Welding Output Terminal A and Welding Output Terminal B

Semi-Automatic Wire Feeder

Eco (Single)	Single	Dual
Welding Wire MIG/MAG: .023 –.030 Self-Shield: .035 –1/16	Welding Wire MIG/MAG: .023 –.045 Self-Shield: .035 –5/64	Welding Wire MIG/MAG: .023 –.030 Self-Shield: .035 –1/16
Welding Output Terminal A		

<Caution>

- Never connect output leads to the output terminals without using crimp on lugs on the leads. Connections without lugs may lead to a high resistance connection resulting in excess heat being developed and burning out of the terminal.
- Side B Output Terminals are for Constant Current Power (CC) only. You cannot get Constant Voltage Power (CV) from the Side B Terminals.

10-4 Duty Cycle

Duty cycle is the percentage of time that welding can be done in a 10 minute period. This equipment has a rated duty cycle of 60%. This means that welding can be performed for 6 minutes within every 10 minute time period.

10-5 Welding

⚠ Caution: Suffocation from welding fumes

- Welding operations may produce fumes and gases that could be hazardous to the operator's health. Do not breathe these fumes and gases. Wear the proper respiratory equipment and provide adequate ventilation whenever welding.

⚠ Caution: Injuries to eyes and skin

- Use shields with the proper filters and cover plates to protect your eyes while welding. Shields and filters should comply with ANSI Z87.1 standards. Wear the proper protective clothing while welding.

⚠ Caution: Fire

- Keep all flammable items an adequate distance from the welding area while welding.

⚠ Caution: Burns

- Always wear appropriate protective clothing and eye protection when welding.

<Caution>

- Never turn the output selector switch while welding. Operation of this switch during welding can cause damage to the switch.

This equipment allows two operators to weld simultaneously with minimal affect on each other. Each operator can individually adjust their own welding current.

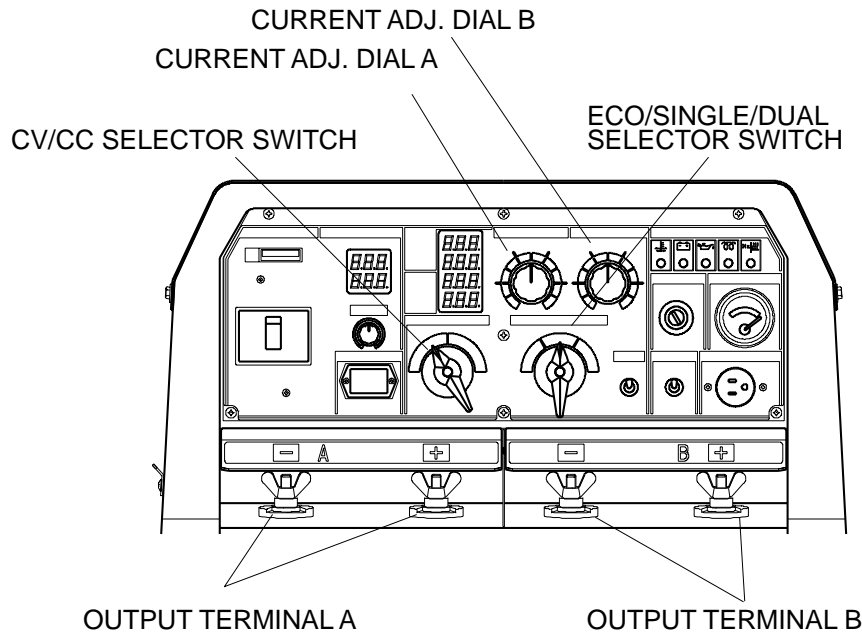

(1) Stick Welding

1. Turn the CV/CC selector switch to CC.
2. Turn the output selector switch to Eco, Single or Dual, according to the desired mode of operation.
3. Adjust welding amperage using the current adjust dial for the side being used (A or B). The following table gives the approximate amperage for the corresponding position on the current adjust dial.

	Position	Welding Current at the dial position						
		MIN	1	2	3	4	5	MAX
1 Person	Eco	40	60	100	140	180	210	220
	Single Use	110	140	200	260	320	380	400
2 Persons	Dual Use	55	70	110	140	170	200	210

These values are approximations only. Factors such as the length of the welding cables and the ambient temperature will affect the actual value.

When the remote control is used, these values may also vary.

(2) Semi-Automatic Wire Feeder

1. Turn the CV/CC selector switch to CV.
2. Turn the output selector switch to Eco, Single or Dual, according to the desired mode of operation.
3. Adjust voltage using the Current Adjust Dial A. Refer to the following table.

	Position		Welding Voltage (V) / Amperage (A) at the dial position						
			MIN	1	2	3	4	5	MAX
1 Person	Eco	V	18	18	19	20	24	25	25
		A	40	50	80	110	200	220	220
	Single Use	V	18	18	20	24	31	34	36
		A	60	60	90	190	270	350	390
2 Persons	Dual Use	V	18	18	20	24	24	24	24
		A	60	60	100	190	210	210	210

These values are approximations only. Factors such as the length of the welding cables and the ambient temperature will affect the actual value.

When the remote control is used, these values may also vary.

11. Generator Operation

11-1 Ratings

Rated Frequency (Hz)	60		
Rated Speed (rpm)	3600		
Phase	1-Phase	1-Phase	3-Phase
Rated Voltage (V)	120	240	480
Power Factor	1.0	1.0	0.8
Rated Output (kVA)	2.2	4.3	15
Rating	Continuous		

3-Phase 480V Output Receptacle

Maximum output from this receptacle is 15KVA (12 kW), 18 amps, at 480 v

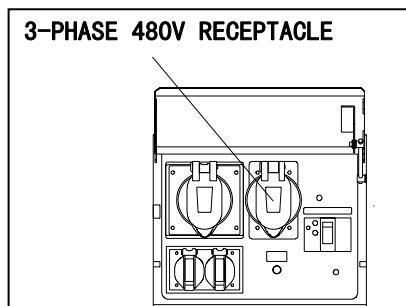

1-Phase 120/240V Output Receptacle

Maximum total single phase output from the 120/240 volt single phase receptacle is 4.3 kVA (4.3 kW), 18 amps at 240 V.

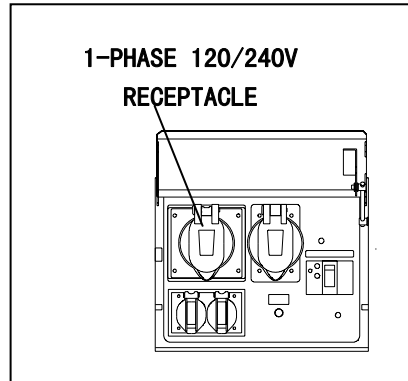

1-Phase 120V Output Receptacle

Maximum total single phase output from the 120 volt duplex receptacle is 2.2 kVA (2.2 kW), 18 amps at 120 V.

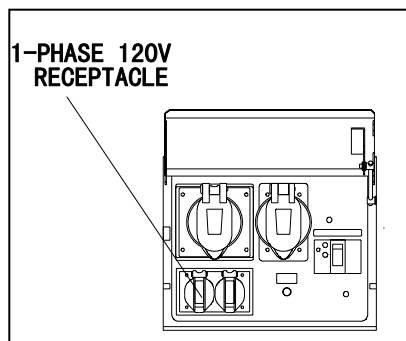

11-2 Operation

⚠ Danger: Electric Shock

- Before connecting or disconnecting load cables to or from the receptacles, turn the circuit breakers (3-P and 1-P) to the OFF position.
- The Earth Grounding Terminal and the enclosure Ground Terminal should always be connected to an earth ground while operating this equipment.
- Grounding connections should be made only with the engine not running.
- If the Earth Leakage Circuit Breaker trips on fault, determine the cause and correct it prior to resetting and shutting the breaker.

⚠ Caution: Injuries

- Do not plug loads into the receptacles until it has been verified that the load on/off switch is in the off position.

<Caution>

- The AC Volt meter reads three phase output voltage whenever the engine is operating, regardless of the position of the single phase and three phase breakers.
1. Start the engine in accordance with Section 7-1 Starting.
 2. Verify that the Three Phase and Single Phase breakers are in the OFF position.
 3. Verify that the load on/off switch is in the off position.
 4. Connect the load to the output receptacles.
 5. Turn the Three Phase and Single Phase circuit breakers to the ON position.
 6. If the electrical demand exceeds the rated output current, the Earth Leakage Circuit Breaker will trip due to overload.

⚠ Caution: Injuries

- Turn all load on/off switches to OFF prior to resetting a tripped Earth Leakage Circuit Breaker.

7. After the cause of the overload has been determined and corrected, reset the circuit breaker by first taking it to the OFF position and then back to the ON position.

12. Simultaneous Use of Welding and Generating

The circuit breakers (3-P and 1-P) are affected only by the AC Generator Output. Simultaneous use of the welder and generator could lead to overloading the engine. Limit AC Generator power use in accordance with the following table.

Welding Output		AC Power Output	
Amperage	Output Selection	3-Phase Output	1-Phase Output
60A	Dual	9.0kVA	4.3kVA
120A	Dual	8.5kVA	4.3kVA
140A	Dual	8.0kVA	4.3kVA
170A	Dual	7.5kVA	4.3kVA
240A	Single	2.5kVA	2.5kVA
300A	Single	2.0kVA	1.5kVA
380A	Single	0kVA	0kVA

<Caution>

- Eco welding power and AC generator power are not available simultaneously.
- Weld quality could be affected when using AC power while welding.

13. Checks and Maintenance

Danger: Electric Shock, Injuries

- Before performing any equipment check or maintenance, stop the engine and remove the engine key. The person performing the maintenance should always retain possession of the key.

Caution: Fire, Burns

- This equipment uses diesel (a flammable liquid) as a fuel. When refueling, always stop the engine and maintain an adequate distance from flames and spark producing devices. Always wait until the engine cools down before refueling.

<Caution>

- With the exception of the pre-startup checks, only qualified technicians should perform checks and maintenance work.
- Those maintenance items marked QT should be performed only by factory trained qualified technicians.
- Use only genuine replacement parts.

To maximize the useful life of this welder/generator, we recommend the periodic equipment checks and maintenance as shown on the table on the following page. Use the hour meter as the guide for the operating time.

Check Items		Startup Check	Check					Every 2000 hrs
			At 50hrs	Every 100 hrs	Every 200 hrs	Every 400 hrs	Every 1000 hrs	
1	Check /Add Fuel	X						
2	Check/ Add Engine Oil	X						
3	Engine Oil Change		1 st X	2 nd or after X				
4	Engine Oil Filter Change		1 st X		2 nd or after X			
5	Check/Add Water/Coolant	X						
6	Water/Coolant Change							X or one year
7	Clean Fuel Strainer		1 st X	2 nd or after X				
8	Change Fuel Filter					X		
9	Drain Water/Clean Fuel Tank				X			
10	Check for Fuel, Oil, and Water Leakage	X						
11	Check/Add Battery Water	X			X Clean	X Change		
12	Clean Air Filter Element		1 st X	2 nd or after X				
13	Change Air Filter Element							
14	Adjust V-Belt Tension		1 st QT	2 nd or after QT				
15	Change V-Belt					QT or 2 years		
16	Clean Radiator Fins					QT		
17	Flush Radiator					QT		
18	Change Fuel Hose, Oil Hose, Vibration-Absorbing Rubber							QT or 2 years
19	Adjust Engine Valve Clearance						QT Adjust	QT Plane
20	Check/Adjust Injection Nozzle					QT		
21	Check/Adjust Injection Pump							QT

1. Oil Change

Frequency

First Time	50 hours
2 nd Time and thereafter	Every 100 hours

Procedure

1. Remove the oil fill cap.
2. Remove the oil drain plug.

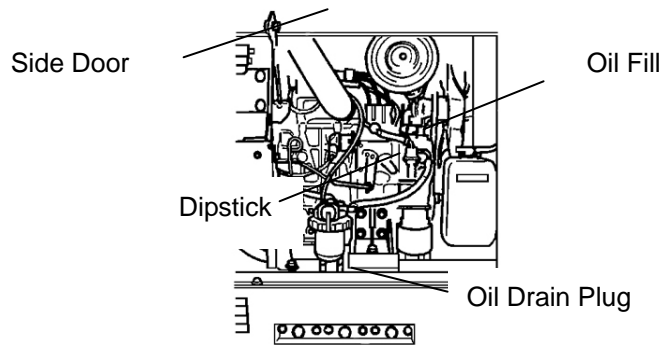

<Caution>

Oil will begin to drain as soon as the oil drain plug is loosened. Ensure there is adequate means to contain the used oil that is being drained.

3. Once the oil is completely drained, reinstall the oil drain plug.
4. Fill the oil to the max level as measured by the dipstick (approximately 4.7 quarts).
5. Reinstall the oil fill cap hand tight.

<Caution>

- Refer to Section 6-1 Checking Engine Oil for the proper weight oil to use.
- Change the packing, whenever changing oil.
- Part No. 6C090-58961 (Kubota part no.)

2. Oil Filter Change

Frequency

First Time	50 hours
2 nd Time and Thereafter	Every 200 hours

Procedure

1. Completely drain the engine oil.
2. Loosen and remove the oil filter.
3. Dampen the new oil filter gasket with clean engine oil.
4. Screw the new filter (Kubota part no. 16271-32090) into place and tighten it by hand until the gasket contacts the seat. Give it an additional 1 1/4 Turns to seat the new filter, using an oil filter wrench.
5. Fill the oil to the max level as measured with the dipstick.

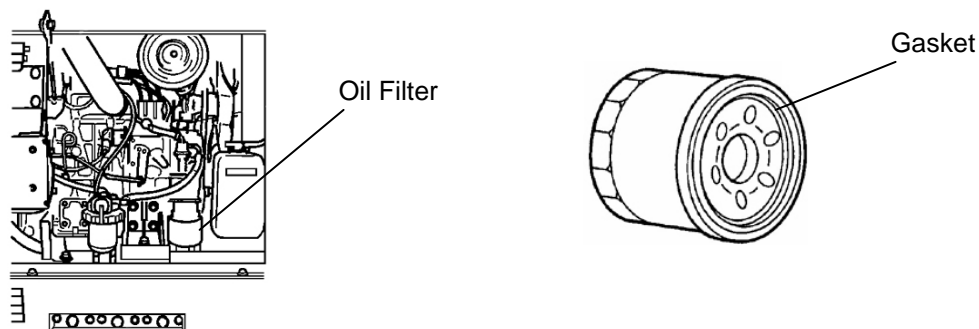

3. Clean/Change Air Filter Element

Frequency

Clean	1 st at 50 hours and Every 100 hours Thereafter
Replace	Every 400 hours

<Caution>

- Clean more frequently, if it is used in dusty environment.

Procedure

1. Loosen the wing bolt on the air cleaner cover and remove the air filter element.
2. Clean or replace the air filter element.
3. Reinstall the air filter element in reverse order (Kubota Part No. 15471-11083).

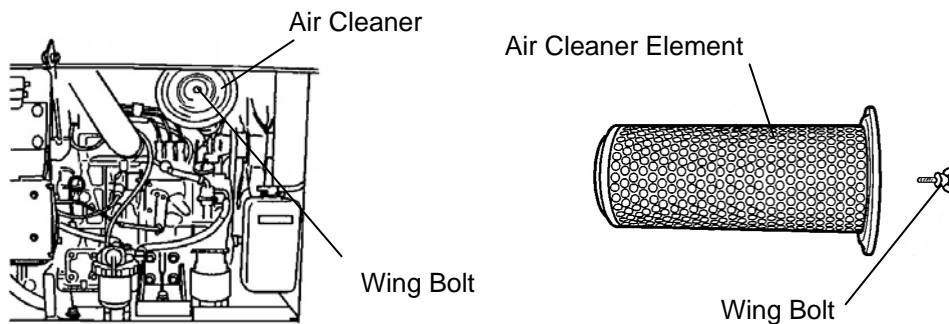

4. Clean/Change Fuel Strainer

Frequency

Clean	1 st at 50 hours and Every 100 hours Thereafter
Replace	Every 400 hours

Procedure

1. Shut the fuel shut off valve.
2. Loosen the fuel filter retaining ring by turning it counterclockwise.
3. Remove the fuel filter bowl and the filter element.
4. Clean the fuel filter bowl.
5. Clean or replace the fuel filter element as required (Kubota Part No. 15521-43161).

6. Reassemble
7. Open the fuel shut off valve and check for leaks.

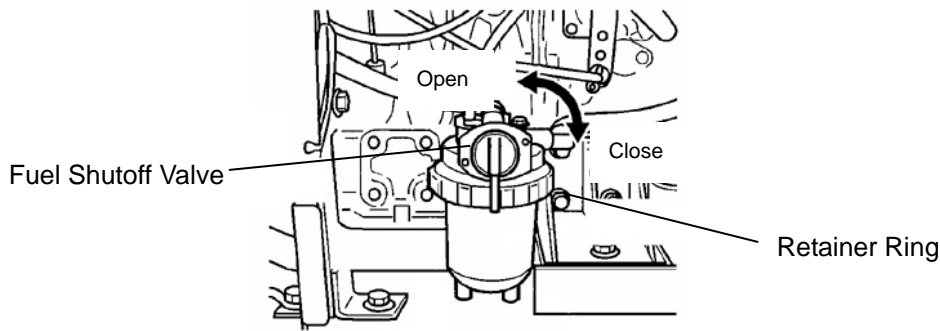

5. Drain Water from Fuel Tank

Frequency

Drain Water	Every 200 hours
-------------	-----------------

Procedure

1. Unscrew the fuel drain plug.

<Caution>

- The contents of the fuel tank will begin to drain as soon as the fuel drain plug is loosened. Ensure there is adequate means to contain the volume of liquid that is being drained.
2. After completely draining the water, reinstall the drain plug.
 3. Refill the fuel tank.

Fuel Drain Plug

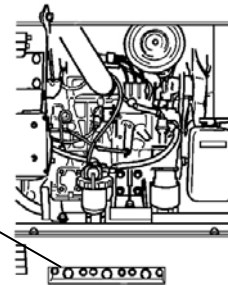

6. Changing Coolant/Water

Frequency

Replace	Every 2 years or 2000 hours
---------	-----------------------------

Procedure

1. Remove the top plate.
2. Remove the radiator cap.
3. Loosen the water drain plug.

<Caution>

- The contents of the coolant system will begin to drain as soon as the water drain plug is loosened. Ensure there is adequate means to contain the volume of liquid that is being drained. Total capacity of the coolant system including the sub tank (1/2 quart) is 4 quarts.

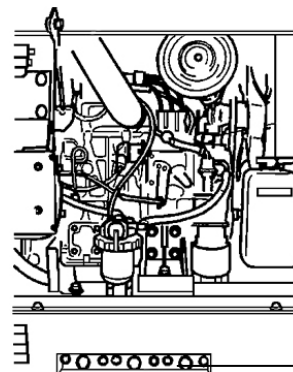

Coolant Drain Plug

4. After draining the water, reinstall the water drain plug.
5. Refill the coolant system with coolant/water to the upper edge of the radiator inlet.
6. Reinstall the radiator cap.
7. Reinstall the top plate.

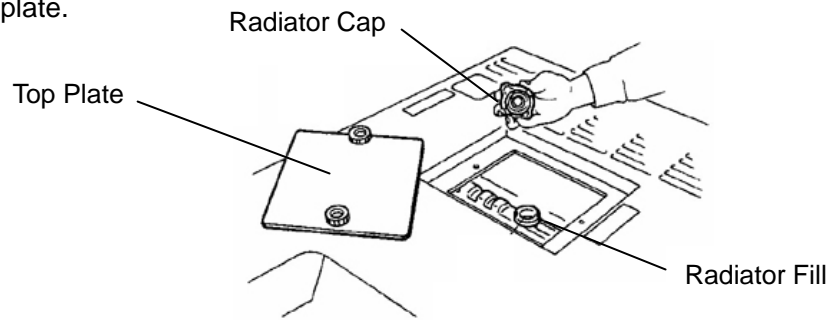

14. Long-Term Storage

⚠ Danger: Electric Shock

- Before performing any equipment check or maintenance, stop the engine and remove the engine key. The person performing the maintenance should always keep the key.

⚠ Caution: Injuries

- Before performing any equipment check or maintenance, stop the engine and remove the engine key. The person performing the maintenance should always keep the key.

If the welder/ generator will not be used for more than two months, perform the following maintenance and storage procedures.

1. Remove the battery.
2. Change the engine oil.
3. Drain all fuel from the fuel tank and the fuel strainer.
4. Cover the welder/generator and keep it in a clean dry location.
5. Recharge the battery once a month.

15. Troubleshooting

⚠ Danger: Electric Shock

- Before performing any equipment check or maintenance, stop the engine and remove the engine key. The person performing the maintenance should always keep the key.

⚠ Caution: Injuries

- Before performing any equipment check or maintenance, stop the engine and remove the engine key. The person performing the maintenance should always keep the key.

⚠ Caution: Fire, Burns

- Before performing any equipment check or maintenance, stop the engine and remove the engine key. The person performing the maintenance should always keep the key.
- Temperatures around the engine, muffler, and exhaust can get extremely high. Allow these areas to cool down before performing any maintenance checks.

Follow the guidelines below when performing any troubleshooting. If you cannot rectify the problem by using this troubleshooting guide, contact the nearest authorized distributor.

Symptoms	Possible Cause	Corrective Actions
Starter motor will not turn over	<ol style="list-style-type: none"> 1. Weak Battery 2. Dead Battery 	<ol style="list-style-type: none"> 1. Recharge Battery 2. Replace Battery
Engine will not start	<ol style="list-style-type: none"> 1. Fuel shutoff valve is closed 2. No fuel 3. Water or contaminants in fuel 4. Fuse burnt out 	<ol style="list-style-type: none"> 1. Open the fuel shutoff valve 2. Refill the fuel tank 3. Drain water/clean fuel tank and fuel strainer 4. Replace
Engine starts, but stalls immediately	<ol style="list-style-type: none"> 1. Insufficient oil 2. Insufficient battery charging 	<ol style="list-style-type: none"> 1. Check oil level and refill if necessary 2. Determine cause and repair
Welding Arc is weak	<ol style="list-style-type: none"> 1. Output selector switch is in Eco or Dual position 2. Wrong current adjustment dial position 3. Welding cables not tightly secured to the output terminals 4. Insufficient Cable Size 5. Poor Contact to work piece 6. Excessive AC power demand 7. Exceeding Duty Cycle (the HZ/Overheat monitor lamp is blinking) 	<ol style="list-style-type: none"> 1. Turn to Single 2. Turn the dial clockwise to increase welding current 3. Connect tightly 4. Change cables 5. Connect securely 6. Reduce AC Power demand 7. Allow the equipment to cool down to where the HZ/Overheat Monitor lamp quits blinking.
Excessive Welding Arc	<ol style="list-style-type: none"> 1. Output selector switch is in the Single position 2. Wrong current adjustment dial position 	<ol style="list-style-type: none"> 1. Turn to ECO or DUAL 2. Turn the dial counterclockwise to reduce welding current
No AC Output	<ol style="list-style-type: none"> 1. The output circuit breakers (3-P or 1-P) are in the off position. 2. Output Selector Switch is in the Eco position 	<ol style="list-style-type: none"> 1. Shut the circuit breakers 2. Turn the Output Selector Switch to SINGLE or DUAL
AC Output is Weak	<ol style="list-style-type: none"> 1. The generator is overloaded. 2. Excessive AC demand while welding. 	<ol style="list-style-type: none"> 1. Reduce welding current or AC power demand 2. Reduce welding current or AC power demand
Slow-Down feature operates erratically.	<ol style="list-style-type: none"> 1. The power consumption of the load is 0.5A or below 	<ol style="list-style-type: none"> 1. Turn the slow-down switch to OFF
Engine does not stop	<ol style="list-style-type: none"> 1. Stop Solenoid malfunction 	<ol style="list-style-type: none"> 1. Shut the fuel shut off valve to stop the engine. 2. Investigate the cause and correct.
Excessive smoke from the muffler	<ol style="list-style-type: none"> 1. Overloaded 	<ol style="list-style-type: none"> 1. Reduce AC load and/or welding current

YAMABIKO CORPORATION

7-2 SUEHIROCHO 1-CHOME, OHME, TOKYO 198-8760, JAPAN
PHONE: 81-428-32-6118. FAX: 81-428-32-6145.

shindaiwa[®]